

PROFESSIONAL MANUFACTURER OF

- SERVO MOTORS
- SERVO DRIVES
- SERVO SYSTEMS



Zhejiang Synmot Electrical Technology Co., Ltd.

Add: Building 27, No. 1111 xiaojiajiang Middle Road,
Xiaogang, Beilun, Ningbo, Zhejiang province, P. R. China
Website: www.synmot.com
www.synmot-electrical.com
Version: E2025-V1.0

Tel: 86-574-87646791
Fax: 86-574-87646798
E-mail: sales@synmot.com



Website

Wechat



India Branch

Synmot Electric Automation Solutions Pvt Ltd

सीनमोट इलेक्ट्रिक ऑटोमेशन सॉल्यूशन प्राइवेट लिमिटेड

Add: (HO)113-114, SAHAJANAND BUSINESS PARK,
OPP PALM HOTEL, ODHAV RING ROAD,
AHMEDABAD, GUJARAT, INDIA

**Synmot Electrical Technology
Co., Ltd.**

CONTENTS

ABOUT SYNROT

APPLICATIONS

SYNROT PRODUCTS

1, Company Profile 03



1, Hydraulic Machinery 06
 2, Textile Machinery 07
 3, CNC Machinery 08



1, Servo Motors 10
 2, Servo Drives 29
 3, Electro-hydraulic Servo Systems 35
 4, Servo-specific EMI Filters 38





Company Profile

Since its establishment more than ten years ago, Zhejiang Synmot Electric Technology Co., Ltd. (Synmot Electric) has been committed to the research and development of high-performance servo motors, motor control devices and electrical energy-saving technologies. Synmot Electric is a professional manufacturer of servo motors, servo drives and complete servo systems. The rated power of Synmot servo motors is 50W-315kW while the rated torque is 0.15 N.m-6000 N.m and the rated speed is 350 rpm-20000 rpm. The rated power of Synmot drives is 0.4 kW-160 kW, which can satisfy the requirement of precise motion control in different industries. Synmot energy-saving systems have been widely used in 50 ton-3000 ton injection molding machinery, die casting machinery, hydraulic machinery, textile machinery, elevators, CNC machine tools, printing and packing, metallurgy and mines etc.

Synmot has a famous electrical professor as the chief engineer. The technical team is composed of Ph.D, masters, senior engineers with strong ability of innovation and engineering. It has more than 30 design patents, and has established cooperation with Zhejiang University in production, design and research. Synmot has laboratories for servo motors, servo drives, EMC and energy-saving technologies, and can develop the specially specified servo system for automatic equipments, CNC machines and inspection devices.

Synmot adopts computerized management systems such as ERP, OA, PLM etc. The enterprise culture is being positive, cooperative and pursuing excellence, takes technology as a guide, pays great attention to the product quality, so as to provide more environment-friendly, more precise and more stable products; to provide the professional solutions in electrical servo systems.

Authorized Certification



FOUR MAJOR APPLICATION FIELDS

Application in Robot



All Series Industrial Robot Joint Motors, 1kg-500kg Entered The Field Of Humanoid Robot Joint Development.

Application in Textile Machinery

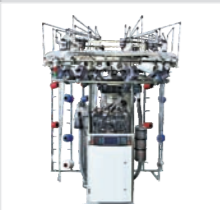

More than 10 years experience of application in textile machinery, with stable quality and high performance, favored by many clients.

Application in CNC Machinery



Widely used in industry robots, CNC machines, etc, with high precision and quick response.

Application in Hydraulic Machinery



Reducing consumption of hydraulic oil and cooling water, extend service life of hydraulic oil, saving energy by 30%-70%.

Application in Other Fields



Synmot cooperates with Zhejiang university to develop a new generation of servo systems, which have been widely used in electric vehicles, food machinery, mining machinery, quay crane and related emerging fields.

Application in Textile Machinery

Features

- ◇ Achieve the direct mechanical feeding mechanism, can greatly reduce the mechanical loss and improve the conversion efficiency of energy.
- ◇ The control method is flexible to achieve various weaving and reduce investment cost.
- ◇ It can meet the needs of different equipment. Comparing with traditional machines, it can significantly improve production efficiency.
- ◇ It can achieve ultra-high-speed, precision and stability control.



Computerized Flat Knitting Machines



Computerized Hosiery Machines



Computerized Embroidery Machines

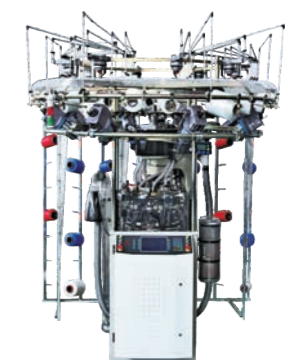

Computerized Circular Knitting Machines

Application in Hydraulic Machinery



Injection Molding Machines

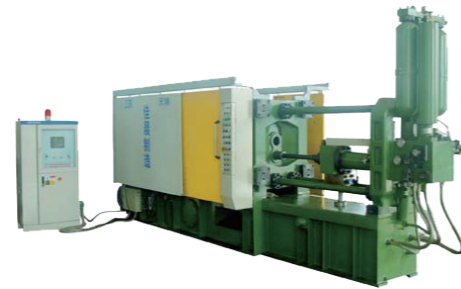

Die Casting Machines



Blow Molding Machines



Hydraulic Press Machines

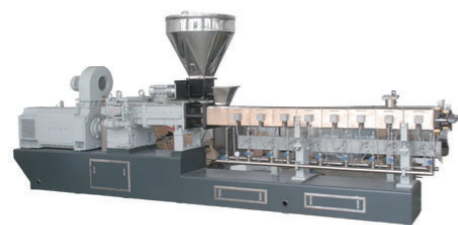

Extruders



Hydraulic Strapping Machines

Application in CNC Machinery

Features

- ◇ Maximum input pulse frequency is 2MHz, a variety of pulse commands can be inputted.
- ◇ It can match with 17/23 bit absolute encoder to ensure high-precision operation.
- ◇ Rich intelligent control functions, electronic gear ratio 4 gear selection, feed-forward compensation, backlash compensation etc, to improve machining precision.
- ◇ Built-in RS485 modbus, CANopen or EtherCAT modbus communication.



Industry Robots



CNC Turret Punch Press Machines

Application in Robot

Features

- ◇ Suitable for high load, high speed, and high efficiency
- ◇ Small cogging torque
- ◇ Low temperature rise, low noise, strong protective ability
- ◇ Various feedback encoders can be selected according to customer requirements



Robot joint motor

SYNMOT PRODUCTS

Servo Motors



Main features:
ultra energy-saving,
high response, high
precision, low noise ,
low temperature rise ,
small volume and high
torque. Using high
resolution encoder ,
so as to reach high
precision of position
control.

Servo Drives



Adopting high-performance
DSP module to control
power frequency,
voltage and motor
speed so as to reach
high efficiency and
precise control.

Electro-hydraulic Servo Systems



Perfectly matched servo
motors, servo drives and oil
pumps, with easy maintenance,
stable performance,
high energy-saving
and high precision.

Servo Motors

Synmot servo motors are permanent magnet synchronous motors, the main features include: ultra energy-saving, high response and high accuracy, low noise and low temperature rise. The rotor is made of high-performance rare-earth permanent magnet material, works reliably and maintenance less. With low rotary inertia, it is easy to improve the rapidity of system, small volume, high speed and high torque. Using the high-resolution encoder(17-bit, 23-bit) to improve the position control accuracy.

Nature-cooling



Forced-air Cooling



Liquid-cooling



High-speed

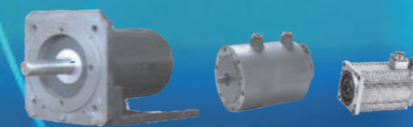

Direct-driven

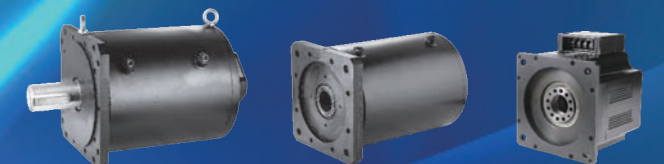

NAMING RULES OF SYNROT SERVO MOTORS

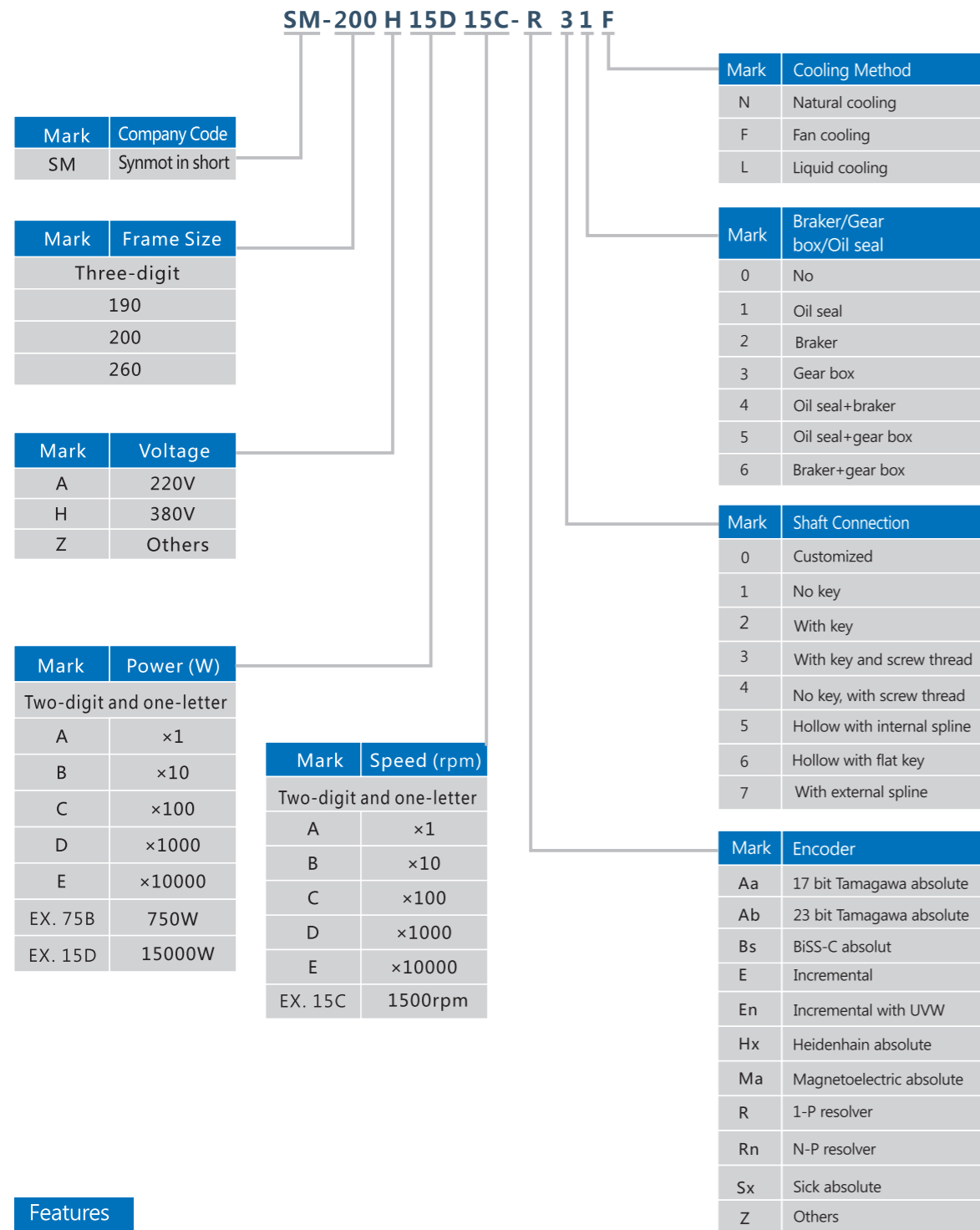

Planetary Geared Servo Motors (natural cooling)

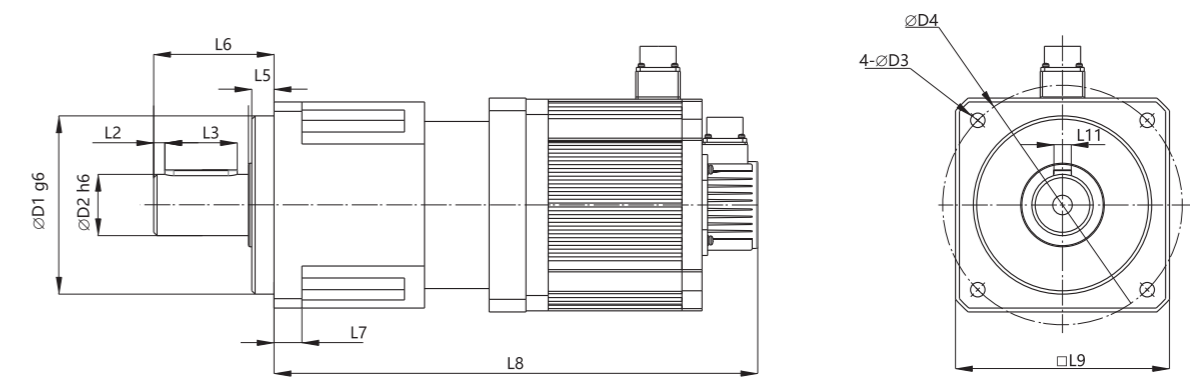

Mounting dimensions

Planetary geared servo motors																			
Model	Rated Power kW	Rated Speed rpm	Rated Voltage Current	Typical Ratio N:1	Output Torque Nm	Output Speed rpm	D1 Mounting Diameter mm	L5 Mounting Length mm	D2 Shaft Diameter mm	L6 Shaft Length mm	L2 Key to Shaft End mm	L3 Key Length mm	L11 Key Width mm	L7 Flange Thickness mm	L9 Flange Square mm	D3 Fixing Hole Dia. mm	D4 Fixing Hole Dis. mm	L8 Length mm	
60A20B30C-RGx	0.2	3000	220V 1.6A	5	3	600	50	7	16	36	2	25	5	8	62	5.5	70	205	
				7	4	428													
				10	6	300													
60A40B30C-RGx	0.4	3000	220V 2.7A	5	6	600	50	7	16	36	2	25	5	8	62	5.5	70	225	
				7	9	428													
				10	13	300													
80A70B30C-RGx	0.75	3000	220V 3.1A	5	11	600	80	10	22	49	3	30	6	12	90	6.6	100	330	
				7	16	428													
				10	22	300													
130A10C20C-RGx	1.0	2000	220V 4.1A	5	32	400	110	12	32	66.5	5	45	10	16	115	9	130	315	
				7	45	286													
				10	64	200													
130A15C15C-RGx	1.5	1500	220V 6.2A	5	48	300	110	12	32	66.5	5	45	10	16	115	9	130	405	
				7	67	214													
				10	96	150													
130A23C15C-RGx	2.3	1500	220V 9.8A	5	73	300	110	12	32	66.5	5	45	10	16	115	9	130	455	
				7	103	214													
				10	146	150													
190H33C15C-RGx	3.3	1500	380V 8.2A	5	105	300	160	20	55	108	10	65	16	26	185	13	215	435	
				7	147	214													
				10	210	150													
190H40C15C-RGx	4.0	1500	380V 10A	5	127	300	160	20	55	108	10	65	16	26	185	13	215	435	
				7	178	214													
				10	255	150													
190H55C15C-RGx	5.5	1500	380V 13A	5	175	300	160	20	55	108	10	65	16	26	185	13	215	465	
				7	245	214													
				10	350	150													
190H75C15C-RGx	7.5	1500	380V 17A	5	239	300	160	20	55	108	10	65	16	26	185	13	215	505	
				7	334	214													
				10	478	150													

Insulation grade: Class-H; Thermal protection: PT100, with KTY optional; Protection grade: IP65; Wiring method: Aviation plug; Braker: Optional; Working standard: Long-term, S1

Features

- ◇ Global optimization of motor using 2D, 3D finite element analysis, low torque-ripple, low noise.
- ◇ Rated power range is from 50 W to 315kW, the motor rated speed is from 350rpm to 20000rpm.
- ◇ High acceleration, quick dynamic response, adopting high-precision incremental or absolute encoder, to achieve high positioning accuracy.

40, 60 , 80 series Servo Motor for Robots Technical Parameters

130, 180, 200 series Servo Motor for Robots Technical Parameters

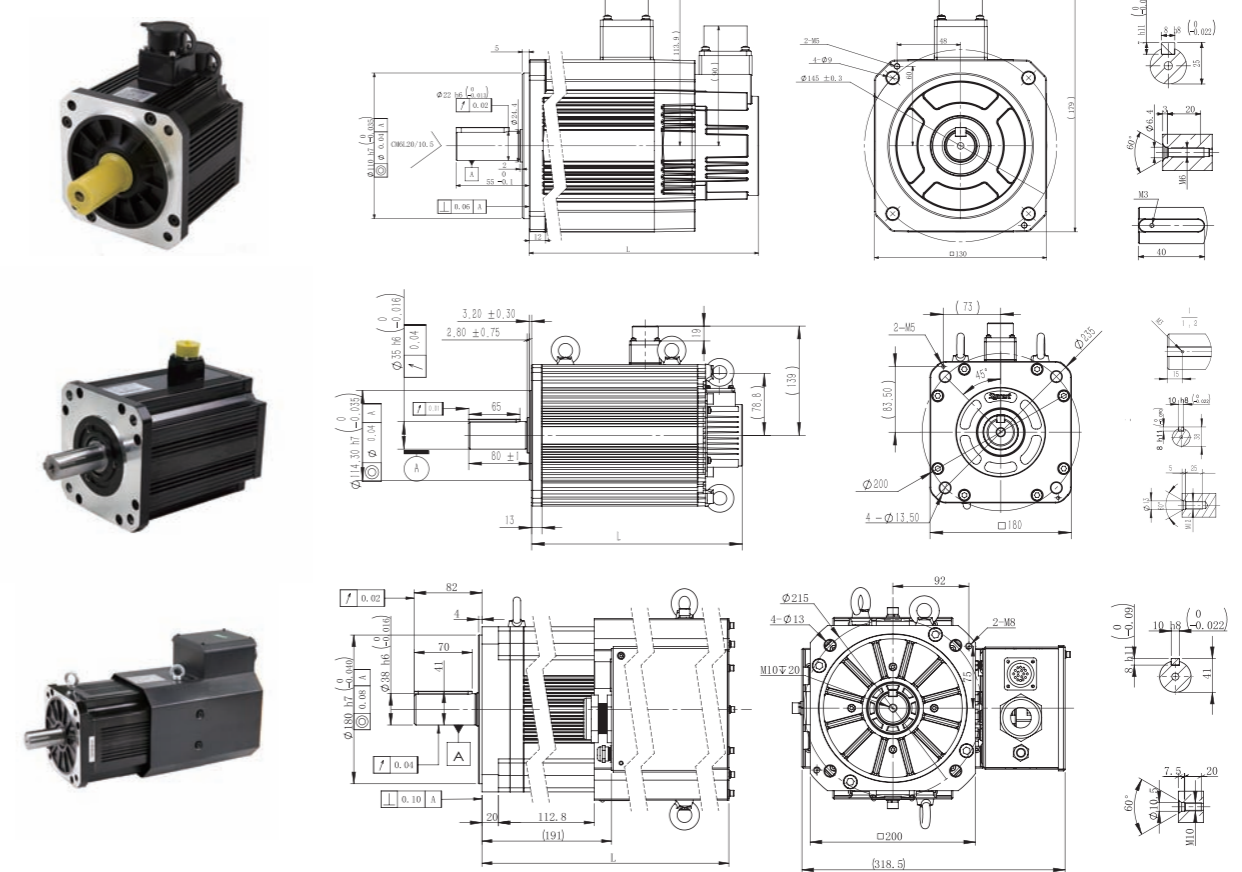
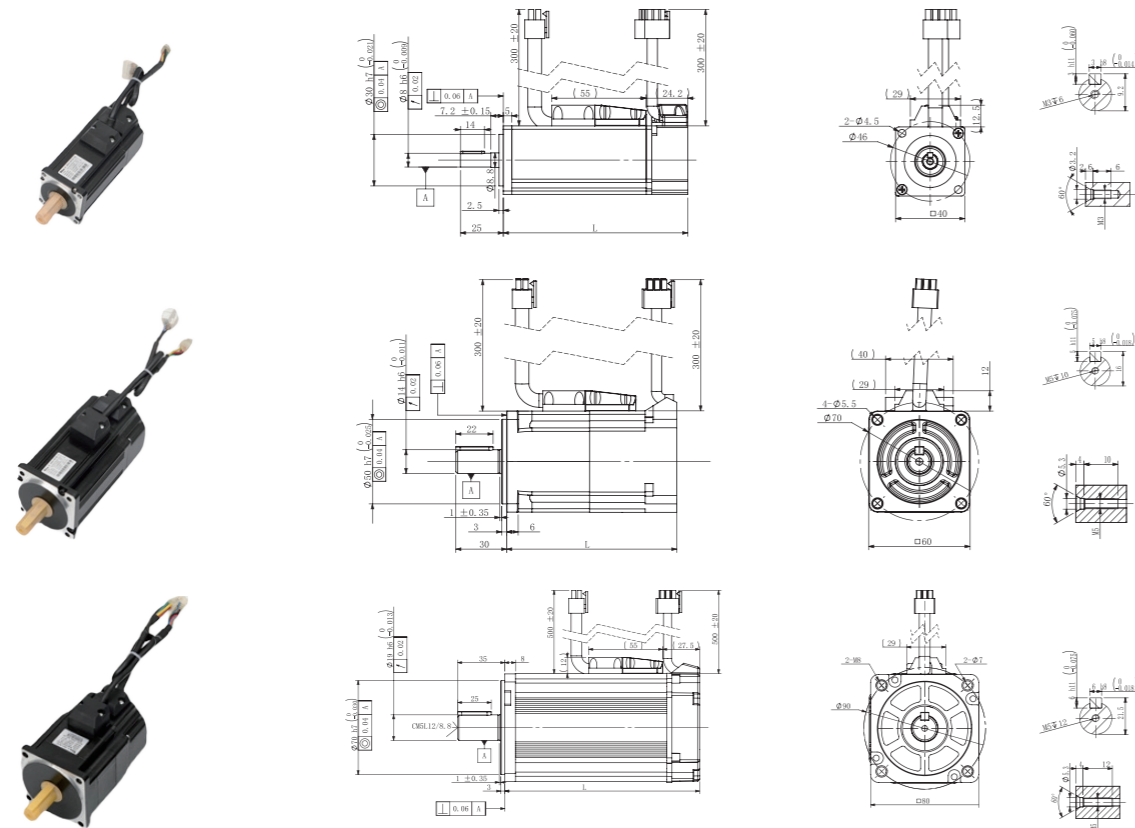

Machine base number 40 (Voltage: 24V 48V 220V 380V optional)

Model	Rated Torque	Rated Voltage	Rated Speed	Rated Power	Rated Current	Kt	Ke	Max. Speed	Max. Torque	Rotor Inertia	Poles	Weight	Length	Length (with braker)
	N.m	Vac	rpm	W	A			N.m/A	V/krpm	rpm				
40A50A30C	0.16	220	3000	50	1.4	0.15	8.8	6000	0.48	0.04	10	0.5	70	90
40A10B30C	0.32	220	3000	100	1.4	0.29	17.3	6000	0.96	0.05	10	0.7	90	110

Motor insulation level: H Protection level: IP65 Holding brake: optional Working system: S1

Machine base number 60 (Voltage: 24V 48V 220V 380V optional)

Model	Rated Torque	Rated Voltage	Rated Speed	Rated Power	Rated Current	Kt	Ke	Max. Speed	Max. Torque	Rotor Inertia	Poles	Weight	Length	Length (with braker)
	N.m	Vac	rpm	W	A			N.m/A	V/krpm	rpm				
60A20B30C	0.64	220	3000	200	1.6	0.47	28.5	6000	1.92	0.33	10	1.2	80	100
60A40B30C	1.27	220	3000	400	3.1	0.48	28.8	6000	3.81	0.56	10	1.5	100	120

Motor insulation level: H Protection level: IP65 Holding brake: optional Working system: S1

Machine base number 80 (Voltage: 24V 48V 220V 380V optional)

Model	Rated Torque	Rated Voltage	Rated Speed	Rated Power	Rated Current	Kt	Ke	Max. Speed	Max. Torque	Rotor Inertia	Poles	Weight	Length	Length (with braker)
	N.m	Vac	rpm	W	A			N.m/A	V/krpm	rpm				
80A75B30C	2.39	220	3000	750	4.9	0.54	32.4	6000	7.17	1.8	10	2.7	109	135
80A10C30C	3.18	220	3000	1000	5.7	0.54	32.4	6000	9.54	2.23	10	3.3	121	149
80H10C30C	3.18	380	3000	1000	3.5	1.0	60.0	5500	9.50	2.00	10	3.2	121	149

Motor insulation level: H Protection level: IP65 Holding brake: optional Working system: S1

Machine base number 130 (Voltage: 24V 48V 220V 380V optional)

Model	Rated Torque	Rated Voltage	Rated Speed	Rated Power	Rated Current	Kt	Ke	Max. Speed	Max. Torque	Rotor Inertia	Poles	Weight	Length	Length (with braker)
	N.m	Vac	rpm	W	A			N.m/A	V/krpm	rpm				
130A17C30C	5.4	220	3000	1700	10.0	0.6	38.8	5000	16.2	10	10	6.2	148	170
130A18C15C	11.46	220	1500	1800	12.5	1.0	59.5	3000	28.7	17	10	8.6	188	201
130H18C15C	11.46	380	1500	1800	6.7	1.9	113	3000	28.7	17	10	9.0	188	201

Motor insulation level: H thermal protection: PT100, KTY optional protection level: IP65 wiring method: aviation plug cooling method: natural cooling brake: optional working system: S1

Machine base number 60

Model	Rated Torque	Rated Voltage	Rated Speed	Rated Power	Rated Current	Kt	Ke	Max. Speed	Max. Torque	Rotor Inertia	Poles	Weight	Length	Length (with braker)
	N.m	Vac	rpm	W	A			N.m/A	V/krpm	rpm				
180A29C20C	14.3	220	2000	2900	13.0	1.2	72	2500	42.9	43	10	18.7	215	268
180H44C15C	28	380	1500	4400	16.3	1.8	111	3000	72	72.2	10	23.2	215	268
180H75C15C	48	380	1500	7500	25.5	1.9	113	2700	120	137.6	10	32.0	275	328

Motor insulation level: H thermal protection: PT100, KTY optional protection level: IP65 wiring method: aviation plug cooling method: natural cooling brake: optional working system: S1

Machine base number 80

Model	Rated Torque	Rated Voltage	Rated Speed	Rated Power	Rated Current	Kt	Ke	Max. Speed	Max. Torque	Rotor Inertia	Poles	Weight	Length	Length (with braker)
	N.m	Vac	rpm	kW	A			N.m/A	V/krpm	rpm				
200H18D15C	110	380	1500	18	35.0	3.4	211	2000	330	264	8	61.0	470	535
200H25D20C	118	380	2000	25	60	2.5	152	2500	354	264	8	61.0	470	535

Motor Insulation Class: H Thermal Protection: PT100, KTY Optional Protection Class: IP65 (excluding hood) Wiring Method: Aviation plug or junction box Cooling Method: Air cooled fan Voltage 220V Work schedule: S1

150mm Permanent Magnet AC Servo Motors
- Technical Parameters (*forced-air cooling*)

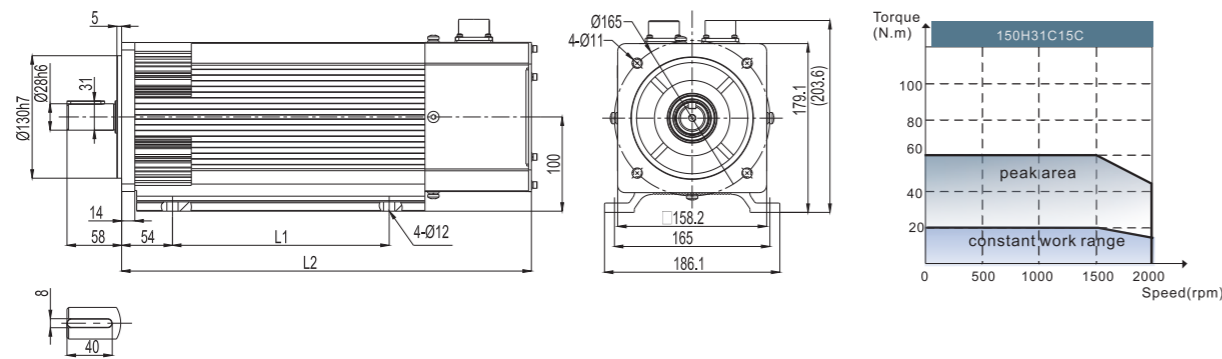
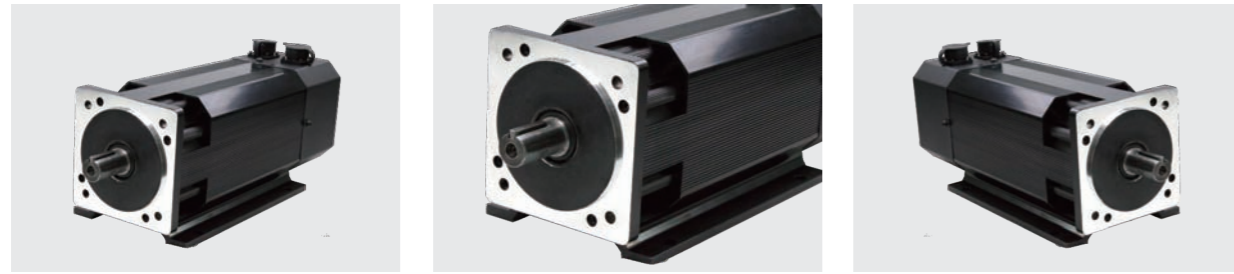

Mounting dimensions of flame size 150 (forced-air cooling)

Flame size 150mm														
Model	Rated Torque	Rated Voltage	Rated Speed	Rated Power	Rated Current	Kt	Ke	Max. Speed	Max. Torque	Rotor Inertia	Poles	Weight	L1	L2
	N.m	Vac	rpm	kW	A	N.m/A	V/krpm	rpm	N.m	Kg.cm ²	poles	Kg	mm	mm
150H31C15C	20	380	1500	3.1	6.9	3.1	187	2000	60	24.9	10	16	70	275
150H40C20C	20	380	2000	4.2	8.8	2.4	147	2500	60	24.9	10	16	70	275
150H44C15C	28	380	1500	4.4	9.6	3.1	189	2000	84	33.5	10	20	100	305
150H60C20C	28	380	2000	5.9	12.2	2.5	149	2500	84	33.5	10	20	100	305
150H55C15C	35	380	1500	5.5	12.0	3.1	189	2000	105	42.2	10	24	130	335
150H75C20C	35	380	2000	7.3	15.2	2.5	149	2500	105	42.2	10	24	130	335
150H75C15C	48	380	1500	7.5	16.5	3.1	187	2000	143	56.6	10	30	180	385
150H10D20C	48	380	2000	10.0	20.9	2.4	148	2500	143	56.6	10	30	180	385
150H95C15C	60	380	1500	9.4	20.8	3.1	187	2000	180	71.0	10	35	230	435
150H13D20C	60	380	2000	12.6	26.4	2.4	147	2500	180	71.0	10	35	230	435

Insulation grade: Class-H; Thermal protection : PT100, with KTY optional; Protection grade: IP65(except the part of the wind hood);
Wiring method: Aviation plug or terminal box; Fan voltage: 220V,with other optional; Working standard: Long-term, S1

180mm Series Permanent Magnet AC Servo Motors
- Technical Parameters (*natural cooling*)

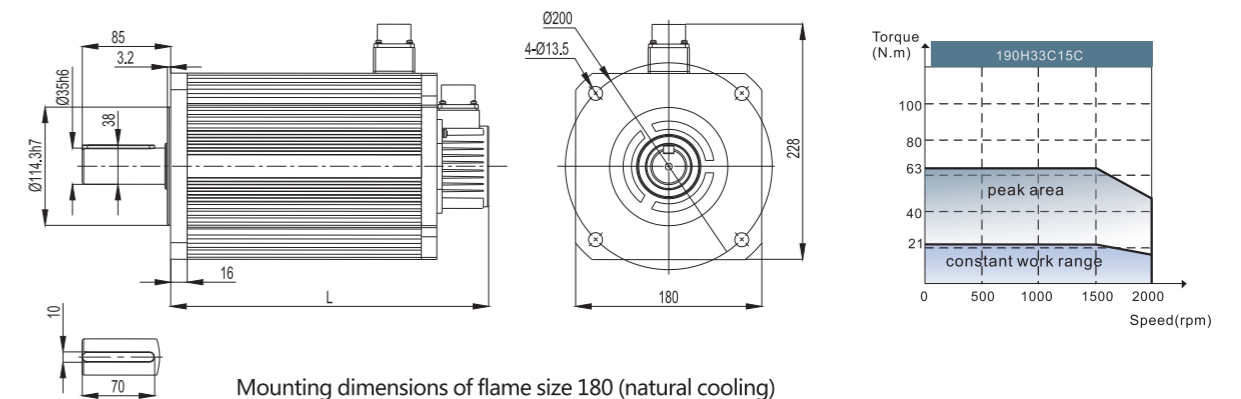
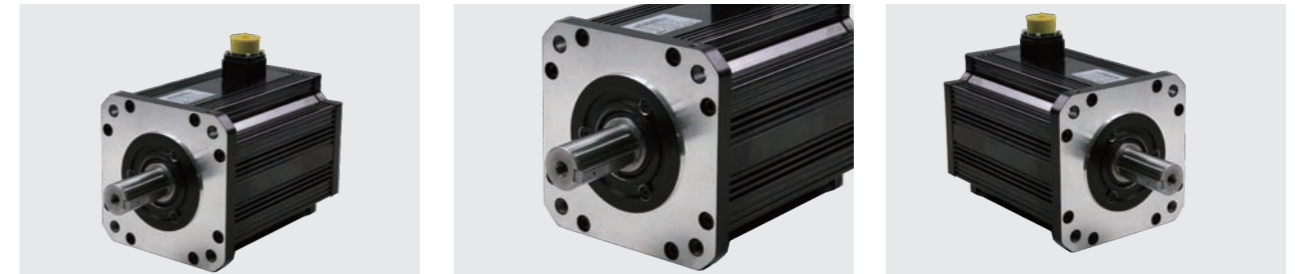

Mounting dimensions of flame size 180 (natural cooling)

Flame size 180mm															
Model	Rated Torque	Rated Voltage	Rated Speed	Rated Power	Rated Current	Kt	Ke	Max. Speed	Max. Torque	Rotor Inertia	Poles	Weight	Length	Length (with braker)	
	N.m	Vac	rpm	kW	A	N.m/A	V/krpm	rpm	N.m	Kg.cm ²	poles	Kg	mm	mm	
180H33C15C	21	380	1500	3.3	6.8	3.4	204	2000	63	46.2	10	20	228	270	
180H44C20C	21	380	2000	4.4	9.0	2.5	154	2500	63	46.2	10	20	228	270	
180H44C15C	28	380	1500	4.4	9.0	3.4	205	2000	84	59.4	10	24	248	290	
180H60C20C	28	380	2000	5.9	11.8	2.6	156	2500	84	59.4	10	24	248	290	
180H55C15C	35	380	1500	5.5	11.2	3.4	206	2000	105	72.5	10	27	268	310	
180H75C20C	35	380	2000	7.3	14.8	2.6	156	2500	105	72.5	10	27	268	310	
180H75C15C	48	380	1500	7.5	15.5	3.4	203	2000	143	98.8	10	30	308	350	
180H10D20C	48	380	2000	10.0	20.2	2.6	156	2500	143	98.8	10	30	308	350	

Insulation grade: Class-H; Thermal protection : PT100, with KTY optional; Protection grade: IP65(except the part of the wind hood);
Wiring method: Aviation plug or terminal box; Fan voltage: 220V,with other optional; Working standard: Long-term, S1

190mm Permanent Magnet AC Servo Motors
- Technical Parameters (natural cooling)

190mm Series Permanent Magnet AC Servo Motors
- Technical Parameters (forced-air cooling)



Size	Type1	Type2
D	32	35
H	35	38

Size	Type1	Type2
D	32	35
H	35	38

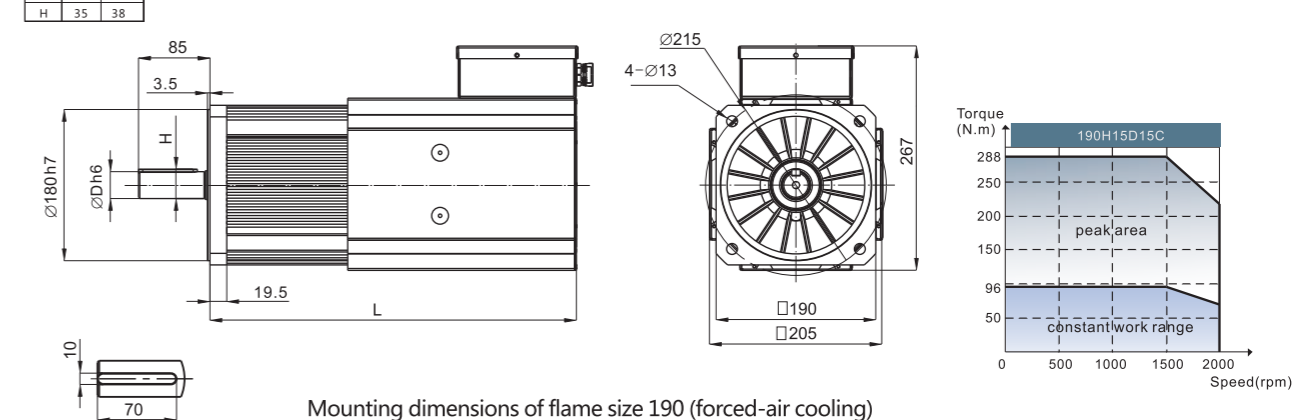
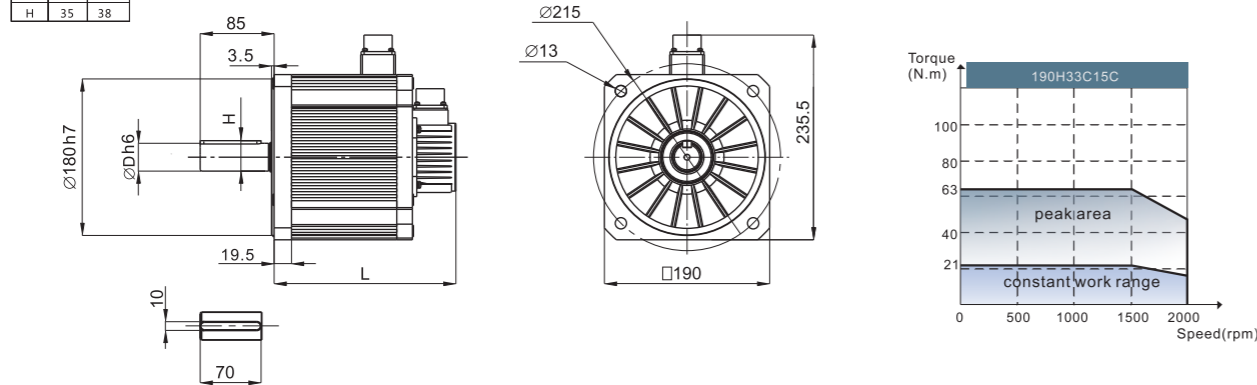

Mounting dimensions of flame size 190 (natural cooling)

Mounting dimensions of flame size 190 (forced-air cooling)

Flame size 190mm														
Model	Rated Torque	Rated Voltage	Rated Speed	Rated Power	Rated Current	Kt	Ke	Max. Speed	Max. Torque	Rotor Inertia	Poles	Weight	Length	Length (with braker)
	N.m	Vac	rpm	kW	A	N.m/A	V/krpm	rpm	N.m	Kg.cm ²	poles	Kg	mm	mm
190H33C15C	21	380	1500	3.3	8.2	2.9	175	2000	63	40	10	16	208	268
190H44C20C	21	380	2000	4.4	10.2	2.3	140	2500	63	40	10	16	208	268
190H55C25C	21	380	2500	5.5	13.0	1.8	110	3000	63	40	10	16	208	268
190H65C30C	21	380	3000	6.5	15.3	1.5	93	3600	63	40	10	16	208	268
190H40C15C	26	380	1500	4.0	9.4	3.0	183	2000	78	47	10	18	208	268
190H55C20C	26	380	2000	5.5	13.2	2.2	135	2500	78	47	10	18	208	268
190H70C25C	26	380	2500	7.0	16.8	1.8	108	3000	78	47	10	18	208	268
190H80C30C	26	380	3000	8.0	19.3	1.5	90	3600	78	47	10	18	208	268
190H55C15C	35	380	1500	5.5	12.6	3.1	189	2000	105	68	10	23	238	338
190H75C20C	35	380	2000	7.5	17.0	2.4	144	2500	105	68	10	23	238	338
190H90C25C	35	380	2500	9.0	20.9	1.9	113	3000	105	68	10	23	238	338
190H11D30C	35	380	3000	11.0	22.5	1.8	108	3600	105	95	10	30	278	338
190H75C15C	48	380	1500	7.5	16.7	3.2	195	2000	144	95	10	30	278	338

Flame size 190mm														
Model	Rated Torque	Rated Voltage	Rated Speed	Rated Power	Rated Current	Kt	Ke	Max. Speed	Max. Torque	Rotor Inertia	Poles	Weight	Length	Length (with braker)
	N.m	Vac	rpm	kW	A	N.m/A	V/krpm	rpm	N.m	Kg.cm ²	poles	Kg	mm	mm
190H11D30C	35	380	3000	11.0	25.4	1.6	95	3600	105	68	10	30	381	441
190H75C15C	48	380	1500	7.5	18.8	2.8	171	2000	144	68	10	30	381	441
190H10D20C	48	380	2000	10.0	23.8	2.2	135	2500	144	90	10	34	381	441
190H13D20C	64	380	2000	13.0	31.8	2.2	135	2500	192	95	10	34	381	441
190H11D15C	70	380	1500	11.0	26.5	2.9	176	2000	210	95	10	34	381	441
190H13D17C	70	380	1700	12.5	27.0	2.9	174	2210	210	95	10	34	381	441
190H15D20C	70	380	2000	15.0	34.4	2.3	137	2500	210	130	10	37	441	496
190H22D30C	70	380	3000	20.0	48.4	1.6	99	3600	210	130	10	37	441	496
190H15D15C	96	380	1500	15.0	32.0	2.8	171	2000	288	130	10	39	441	496
190H17D17C	96	380	1700	17.0	37.5	2.8	172	2210	288	130	10	39	441	496
190H20D20C	96	380	2000	20.0	43.0	2.4	147	2500	288	130	10	39	441	496
190H19D15C	118	380	1500	18.5	40.0	3.2	195	2000	354	145	10	41	456	516
190H21D17C	118	380	1700	21.0	45.0	2.9	173	2210	354	145	10	41	456	516
190H25D20C	118	380	2000	25.0	56.0	2.3	141	2500	354	145	10	41	456	516
190H22D15C	140	380	1500	22.0	48.0	3.2	195	2000	420	172	10	45	496	556
190H25D17C	140	380	1700	25.0	55.0	2.8	169	2210	420	172	10	45	496	556
190H29D20C	140	380	2000	29.0	65.0	2.4	143	2500	420	172	10	45	496	556
190H29D20C	140	380	2000	29.0	65.0	2.4	143	2500	420	172	10	45	496	556

Insulation grade: Class-H; Thermal protection : PT100, with KTY optional; Protection grade: IP65;
Wiring method: Aviation plug; Braker: Optional; Working standard: Long-term, S1

Insulation grade: Class-H; Thermal protection : PT100, with KTY optional; Protection grade: IP65(except the part of the wind hood);
Wiring method: Terminal box; Fan voltage: 220V,with other optional; Working standard: Long-term, S1 1

200mm Permanent Magnet AC Servo Motors
- Technical Parameters (*forced-air cooling*)

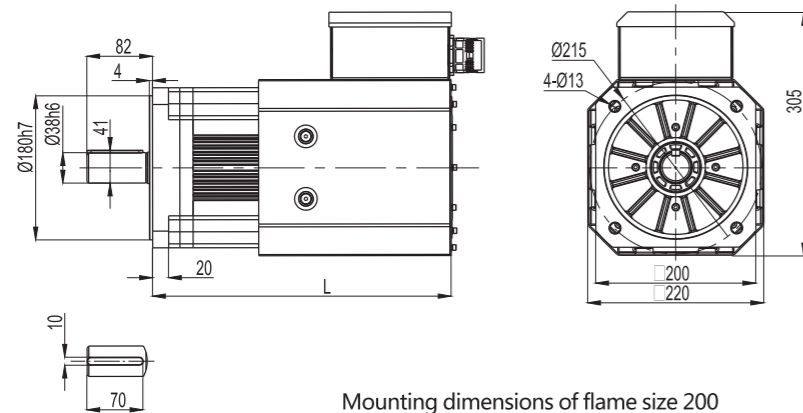

Mounting dimensions of flame size 200

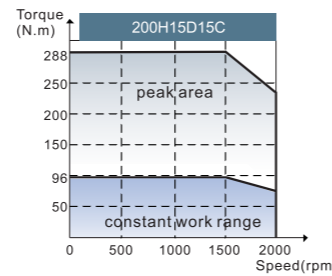

Flame size 200mm

Model	Rated Torque	Rated Voltage	Rated Speed	Rated Power	Rated Current	Kt	Ke	Max. Speed	Max. Torque	Rotor Inertia	Poles	Weight	Length
	N.m	Vac	rpm	kW	A								
200H75C15C	50	380	1500	7.5	17	3.2	200	2000	150	112	8	30	336
200H90C17C	50	380	1700	9	20	2.8	172	2210	150	112	8	30	336
200H11D20C	50	380	2000	11	23	2.4	150	2500	150	112	8	30	336
200H11D15C	70	380	1500	11	23	3.3	203	2000	210	163	8	41	373
200H13D17C	70	380	1700	13	26	2.9	182	2210	210	163	8	41	373
200H15D20C	70	380	2000	15	32	2.4	150	2500	210	163	8	41	373
200H15D15C	96	380	1500	15	33	3.2	200	2000	288	213	8	50	410
200H17D17C	96	380	1700	17	36	3.0	185	2210	288	213	8	50	410
200H20D20C	96	380	2000	20	41	2.5	157	2500	288	213	8	50	410
200H18D15C	118	380	1500	18	38	3.3	205	2000	354	264	8	58	447
200H21D17C	118	380	1700	21	42	3.1	186	2210	354	264	8	58	447
200H25D20C	118	380	2000	25	53	2.5	152	2500	354	264	8	58	447
200H22D15C	140	380	1500	22	46	3.3	203	2000	420	314	8	66	484
200H25D17C	140	380	1700	25	52	2.9	182	2210	420	314	8	66	484
200H29D20C	140	380	2000	29	59	2.6	160	2500	420	314	8	66	484
200H25D15C	157	380	1500	25	49	3.5	211	2000	471	314	8	67	484
200H28D17C	157	380	1700	28	55	3.1	189	2210	471	314	8	67	484
200H33D20C	157	380	2000	33	66	2.6	156	2500	471	314	8	67	484
200H18D10C	176	380	1000	18	36	5.4	324	1500	528	365	8	77	521
200H28D15C	176	380	1500	28	53	3.6	220	2000	528	365	8	77	521
200H31D17C	176	380	1700	31	60	3.2	194	2210	528	365	8	77	521
200H37D20C	176	380	2000	37	69	2.8	168	2500	528	365	8	77	521

Insulation grade: Class-H; Thermal protection : PT100, with KTY optional; Protection grade: IP65(except the part of the wind hood); Wiring method: Terminal box; Fan voltage: 220V,with other optional; Working standard: Long-term, S1

260mm Series Permanent Magnet AC Servo Motors
- Technical Parameters (*forced-air cooling*)



Size	<287 N.m	≥287 N.m
D	42	48
H	45	50.5
W	12	14

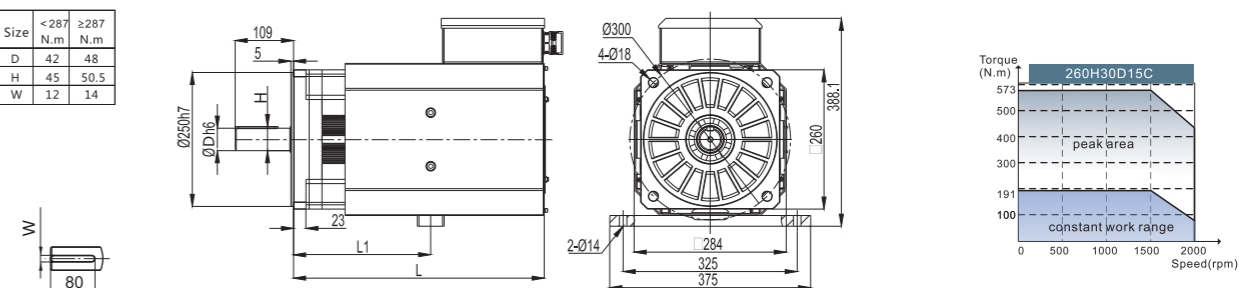

Mounting dimensions of flame size 260

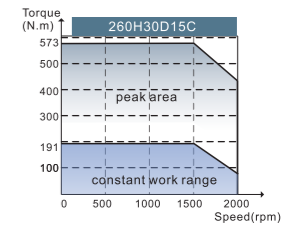

Flame size 260mm

Model	Rated Torque	Rated Voltage	Rated Speed	Rated Power	Rated Current	Kt	Ke	Max. Speed	Max. Torque	Rotor Inertia	Poles	Weight	L1	L
	N.m	Vac	rpm	kW	A									
260H30D15C	191	380	1500	30	62	3.3	198	2000	573	386	8	92	/	468
260H34D17C	191	380	1700	34	69	3.0	180	2300	573	386	8	92	/	468
260H40D20C	191	380	2000	40	81	2.5	153	2500	573	386	8	92	/	468
260H33D15C	208	380	1500	33	67	3.4	204	2000	624	434	8	102	/	488
260H37D17C	208	380	1700	37	74	3.0	183	2300	624	434	8	102	/	488
260H44D20C	208	380	2000	44	89	2.5	153	2500	624	434	8	102	/	488
260H37D15C	236	380	1500	37	75	3.4	204	2000	708	482	8	109	296	508
260H42D17C	236	380	1700	42	85	3.0	181	2300	708	482	8	109	296	508
260H50D20C	236	380	2000	50	105	2.4	147	2500	708	482	8	109	296	508
260H42D15C	264	380	1500	42	84	3.4	204	2000	792	542	8	120	321	533
260H47D17C	264	380	1700	47	96	3.0	179	2300	792	542	8	120	321	533
260H56D20C	264	380	2000	56	112	2.5	153	2500	792	542	8	120	321	533
260H45D15C	287	380	1500	45	94	3.3	199	2000	861	601	8	131	346	558
260H51D17C	287	380	1700	51	101	3.1	185	2300	861	601	8	131	346	558
260H60D20C	287	380	2000	60	120	2.6	156	2500	861	601	8	131	346	558
260H50D15C	315	380	1500	50	103	3.3	200	2000	945	649	8	138	366	578
260H56D17C	315	380	1700	56	111	3.1	185	2300	945	649	8	138	366	578
260H66D20C	315	380	2000	66	134	2.5	154	2500	945	649	8	138	366	578
260H55D15C	350	380	1500	55	117	3.2	195	2000	1050	745	8	152	406	618
260H62D17C	350	380	1700	62	129	2.9	177	2300	1050	745	8	152	406	618
260H73D20C	350	380	2000	73	144	2.6	159	2500	1050	745	8	152	406	618
260H66D15C	420	380	1500	66	142	3.2	193	2000	1260	900	8	174	471	698
260H75D17C	420	380	1700	75	160	2.8	172	2300	1260	900	8	174	471	698
260H88D20C	420	380	2000	88	183	2.5	150	2500	1260	900	8	174	471	698
260H75D15C	480	380	1500	75	158	3.3	199	2000	1440	1043	8	200	531	765
260H85D17C	480	380	1700	85	180	2.9	174	2300	1440	1043	8	200	531	765
260H10E20C	480	380	2000	100	211	2.5	150	2500	1440	1043	8	200	531	765
260H90D15C	570	380	1500	90	184	3.4	203	2000	1710	1210	8	210	607	835
260H10E17C	560	380	1700	100	211	2.9	174	2300	1680	1210	8	210	607	835
260H11E20C	550	380	2000	115	249	2.4	145	2500	1650	1210	8	210	607	835

Insulation grade: Class-H; Thermal protection : PT100, with KTY optional; Protection grade: IP65(except the part of the wind hood); Wiring method: Terminal box; Fan voltage: 220V,with other optional; Working standard: Long-term, S1

360mm Series Permanent Magnet AC Servo Motors
- Technical Parameters (*forced-air cooling*)

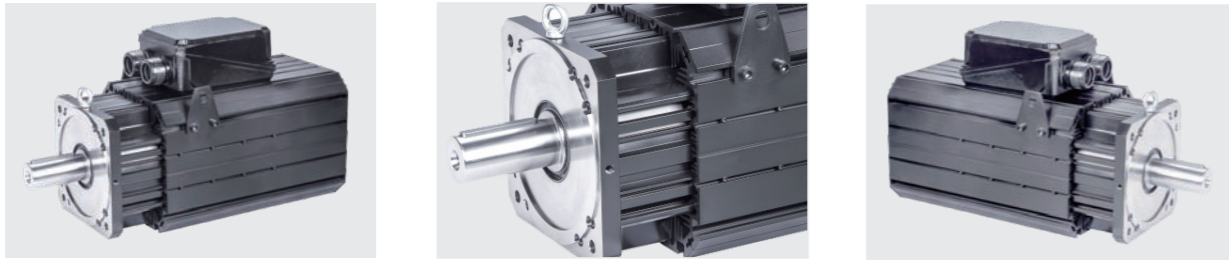

Torque (N.m)	D	H	W
<1480	80	85	22
≥1480	85	90	22

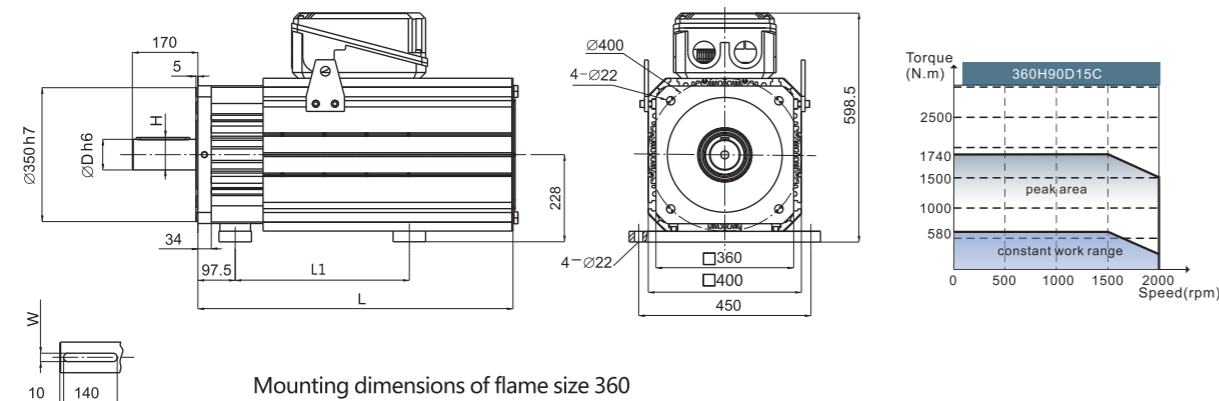

Mounting dimensions of flame size 360

Flame size 360mm														
Model	Rated Torque	Rated Voltage	Rated Speed	Rated Power	Rated Current	Kt	Ke	Max. Speed	Max. Torque	Rotor Inertia	Poles	Weight	L1	L
	N.m	Vac	rpm	kW	A	N.m/A	V/krpm	rpm	N.m	Kg.cm ²	poles	Kg	mm	mm
360H63D10C	600	380	1000	63	139	4.7	284	1500	1800	2519	8	340	385	730
360H90D15C	580	380	1500	90	196	3.2	195	2000	1740	2519	8	340	385	730
360H11E20C	530	380	2000	110	196	2.6	160	2500	1590	2519	8	340	385	730
360H76D10C	730	380	1000	76	171	4.6	281	1500	2190	2907	8	383	485	830
360H11E15C	700	380	1500	110	238	3.2	194	2000	2100	2907	8	383	485	830
360H13E20C	650	380	2000	136	238	2.5	151	2500	1950	2907	8	383	485	830
360H90D10C	860	380	1000	90	202	4.6	280	1500	2580	3295	8	390	485	830
360H13E15C	830	380	1500	130	269	3.4	204	2000	2490	3295	8	390	485	830
360H16E20C	770	380	2000	160	269	2.5	153	2500	2310	3295	8	390	485	830
360H11E10C	1100	380	1000	115	248	4.8	291	1500	3300	4168	8	470	675	1020
360H16E15C	1050	380	1500	165	356	3.2	194	2000	3150	4168	8	470	675	1020
360H20E20C	950	380	2000	200	347	2.7	162	2500	2850	4168	8	470	675	1020
360H14E10C	1340	380	1000	140	314	4.6	281	1500	4020	4943	8	485	675	1020
360H20E15C	1280	380	1500	200	422	3.3	200	2000	3840	4943	8	485	675	1020
360H24E20C	1150	380	2000	240	422	2.7	160	2500	3450	4943	8	485	675	1020
360H17E10C	1620	380	1000	170	371	4.7	287	1500	4860	5841	8	540	775	1120
360H25E15C	1600	380	1500	250	551	3.2	191	2000	4800	5841	8	540	775	1120
360H31E20C	1480	380	2000	310	683	2.4	143	2500	4440	5841	8	540	775	1120

Insulation grade: Class-H; Thermal protection : PT100, with KTY optional; Protection grade: IP65(except the part of the wind hood); Wiring method: Terminal box; Fan voltage: 220V,with other optional; Working standard: Long-term, S1

110mm, 170mm, 215mm Permanent Magnet AC Servo Motors
- Technical Parameters (*high-speed*)

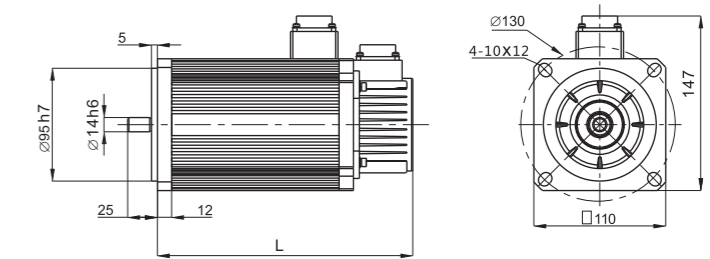

Mounting dimensions of flame size 110

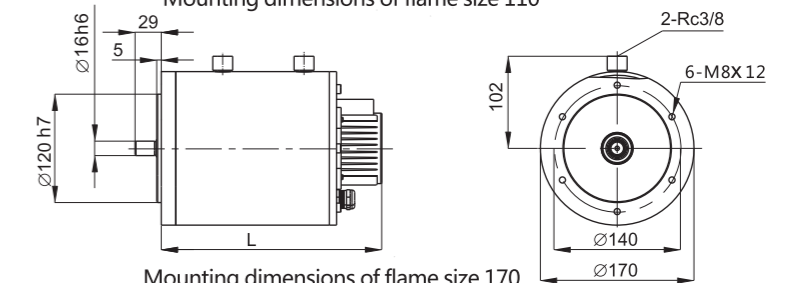

Mounting dimensions of flame size 170

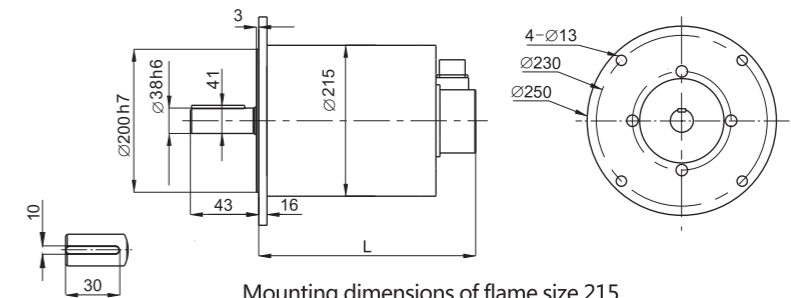

Mounting dimensions of flame size 215

Flame size 110mm														
Model	Rated Torque	Rated Voltage	Rated Speed	Rated Power	Rated Current	Kt	Ke	Max. Speed	Max. Torque	Rotor Inertia	Poles	Weight	Length	
	N.m	Vac	rpm	kW	A	N.m/A	V/krpm	rpm	N.m	Kg.cm ²	poles	Kg	mm	
110H15C70C	2.1	380	7000	1.5	3.2	0.8	46.7	8000	6.2	3.5	4	11	215	
110H15C80C	1.8	380	8000	1.5	3.1	0.7	41.1	9000	5.4	3.5	4	11	215	

Flame size 170mm														
Model	Rated Torque	Rated Voltage	Rated Speed	Rated Power	Rated Current	Kt	Ke	Max. Speed	Max. Torque	Rotor Inertia	Poles	Weight	Length	
	N.m	Vac	rpm	kW	A	N.m/A	V/krpm	rpm	N.m	Kg.cm ²	poles	Kg	mm	
170H80C80C	9.5	380	8000	8	17	0.63	38.3	10000	19.0	3.5	4	26	244	
170H11D12D	8.8	380	12000	11	24	0.41	25.0	14000	17.6	3.5	4	26	244	
170H15D20D	7.2	380	20000	15	31	0.27	16.2	22000	14.4	3.5	4	26	244	
170H22D20D	10.5	380	20000	22	46	0.26	15.7	22000	21.0	4.5	4	28	265	

Flame size 215mm														
Model	Rated Torque	Rated Voltage	Rated Speed	Rated Power	Rated Current	Kt	Ke	Max. Speed	Max. Torque	Rotor Inertia	Poles	Weight	Length	
	N.m	Vac	rpm	kW	A	N.m/A	V/krpm	rpm	N.m	Kg.cm ²	poles	Kg	mm	
215A11D50C	21.0	220	5000	11	38	0.6	36.1	7000	42.0	33	4	41	163	
215A13D50C	24.8	220	5000	13	45	0.6	36.0	7000	49.6	38	4	43	170	
215H22D50C	42.0	380	5000	22	42	1.1	65.3	7000	84.0	68	4	53	210	
215H30D50C	57.4	380	5000	30	57	1.1	65.8	7000	114.8	96	4	63	250	
215H37D50C	70.7	380	5000	37	70	1.1	66.0	7000	141.4	123	4	75	300	
215H50D50C	95.5	380	5000	50	94	1.1	66.4	7000	191.0	184	4	93	370	

Insulation grade: Class-H; Thermal protection : PT100, with KTY optional; Protection Grade: IP67; Working standard: Long-term, S1

200mm Permanent Magnet AC Servo Motors
- Technical Parameters (liquid cooling)

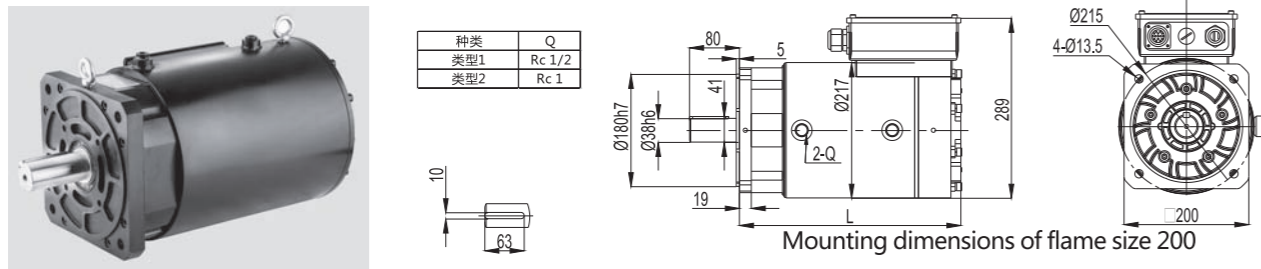

Flame size 200mm													
Model	Rated Torque	Rated Voltage	Rated Speed	Rated Power	Rated Current	Kt	Ke	Max. Speed	Max. Torque	Rotor Inertia	Poles	Weight	Length
	N.m	Vac	rpm	kW	A	N.m/A	V/krpm	rpm	N.m	Kg.cm ²	poles	Kg	mm
200H11D15C	72	380	1500	11	25	3.2	192	2000	216	88	8	33	295
200H13D17C	72	380	1700	13	29	2.8	169	2300	216	88	8	33	295
200H15D20C	72	380	2000	15	33	2.4	146	2500	216	88	8	33	295
200H15D15C	96	380	1500	15	34	3.1	189	2000	288	109	8	37	355
200H17D17C	96	380	1700	17	38	2.8	169	2300	288	109	8	37	355
200H20D20C	96	380	2000	20	44	2.4	144	2500	288	109	8	37	355
200H18D15C	118	380	1500	19	40	3.2	196	2000	354	130	8	48	355
200H21D17C	118	380	1700	21	46	2.8	171	2300	354	130	8	48	355
200H25D20C	118	380	2000	25	54	2.4	147	2500	354	130	8	48	355
200H22D15C	141	380	1500	22	48	3.3	198	2000	423	160	8	57	435
200H25D17C	141	380	1700	25	54	2.9	175	2300	423	160	8	57	435
200H30D20C	141	380	2000	30	62	2.5	153	2500	423	160	8	57	435
200H27D15C	170	380	1500	27	56	3.3	201	2000	510	187	8	68	435
200H30D17C	170	380	1700	30	65	2.9	174	2300	510	187	8	68	435
200H36D20C	170	380	2000	36	73	2.6	156	2500	510	187	8	68	435

Insulation grade: Class-H; Thermal protection : PT100, with KTY optional; Protection grade: IP65 (except the terminal box);
 Wiring method: Terminal box; Cooling method: Oil-cooling or water-cooling; Working standard: Long-term, S1

260mm Permanent Magnet AC Servo Motors
- Technical Parameters (liquid cooling)

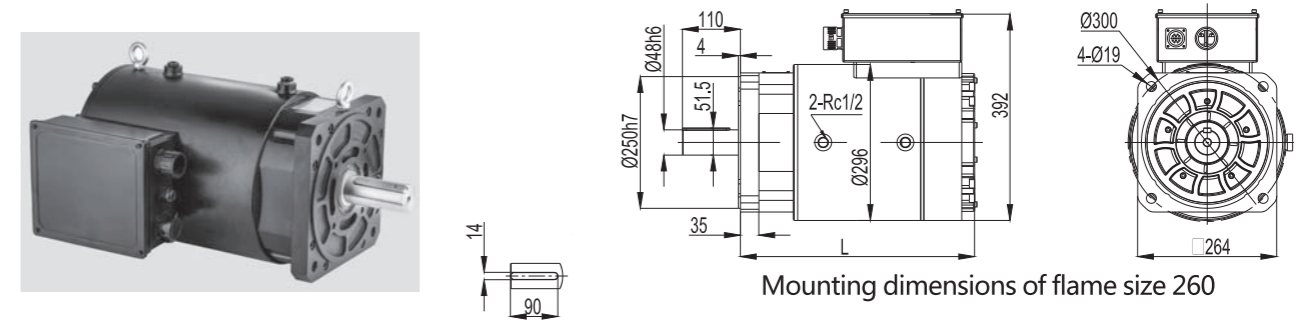

Flame size 260mm													
Model	Rated Torque	Rated Voltage	Rated Speed	Rated Power	Rated Current	Kt	Ke	Max. Speed	Max. Torque	Rotor Inertia	Poles	Weight	Length
	N.m	Vac	rpm	kW	A	N.m/A	V/krpm	rpm	N.m	Kg.cm ²	poles	Kg	mm
260H33D15C	208	380	1500	33	70	3.3	197	2000	624	430	8	110	457
260H37D17C	208	380	1700	37	79	2.9	173	2300	624	430	8	110	457
260H44D20C	208	380	2000	44	92	2.5	150	2500	624	430	8	110	457
260H41D15C	264	380	1500	41	89	3.2	196	2000	792	546	8	120	457
260H47D17C	264	380	1700	47	100	2.9	175	2300	792	546	8	120	457
260H55D20C	264	380	2000	55	113	2.5	154	2500	792	546	8	120	457
260H50D15C	316	380	1500	50	107	3.2	195	2000	948	644	8	125	542
260H56D17C	316	380	1700	56	123	2.8	171	2300	948	644	8	125	542
260H66D20C	316	380	2000	66	143	2.4	146	2500	948	644	8	125	542
260H60D15C	384	380	1500	60	122	3.4	208	2000	1152	772	8	139	542
260H68D17C	384	380	1700	68	143	3.0	179	2300	1152	772	8	139	542
260H80D20C	384	380	2000	80	171	2.5	149	2500	1152	772	8	139	542
260H75D15C	480	380	1500	75	153	3.4	208	2000	1440	978	8	158	687
260H85D17C	480	380	1700	85	168	3.1	189	2300	1440	978	8	158	687
260H10E20C	480	380	2000	100	211	2.5	151	2500	1440	978	8	158	687
260H90D15C	570	380	1500	90	185	3.4	204	2000	1710	1158	8	175	687
260H10E17C	570	380	1700	100	208	3.0	182	2300	1710	1158	8	175	687
260H11E20C	550	380	2000	115	231	2.6	159	2500	1650	1158	8	175	687

Insulation grade: Class-H; Thermal protection : PT100, with KTY optional; Protection grade: IP65 (except the terminal box);
 Wiring method: Terminal box; Cooling method: Oil-cooling or water-cooling; Working standard: Long-term, S1

360mm, 450mm Permanent Magnet AC Servo Motors - Technical Parameters (liquid cooling)

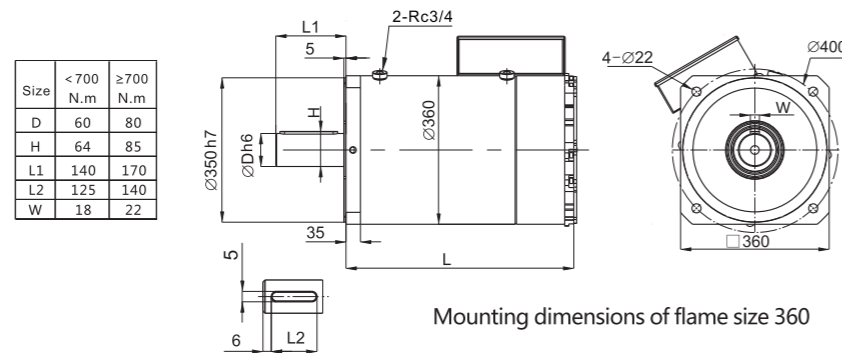

Size	< 700 N.m	≥ 700 N.m
D	60	80
H	64	85
L1	140	170
L2	125	140
W	18	22

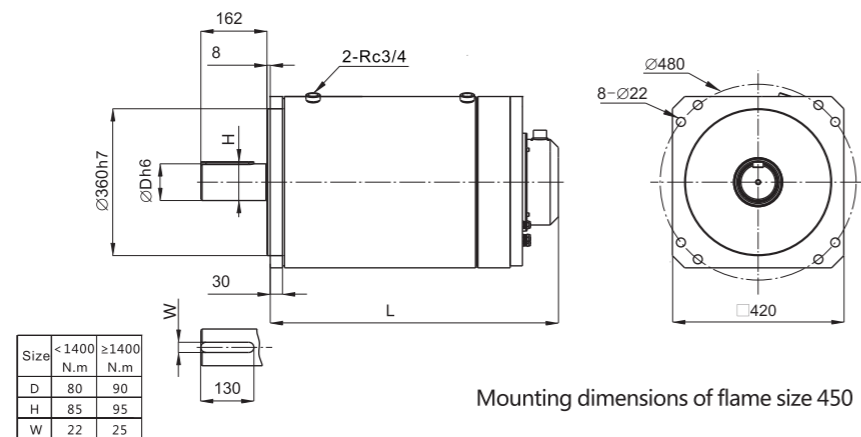

Size	< 1400 N.m	≥ 1400 N.m
D	80	90
H	85	95
W	22	25

Flame size 360mm

Model	Rated Torque	Rated Voltage	Rated Speed	Rated Power	Rated Current	Kt	Ke	Max. Speed	Max. Torque	Rotor Inertia	Poles	Weight	Length
	N.m	Vac	rpm	kW	A	N.m/A	V/krpm	rpm	N.m	Kg.cm ²	poles	Kg	mm
360H75D15C	480	380	1500	75	174	3.1	187	2000	960	1982	8	228	509
360H90D15C	575	380	1500	90	201	3.2	194	2000	1150	2356	8	250	559
360H11E15C	700	380	1500	110	255	3.1	187	2000	1400	2729	8	272	609
360H14E15C	900	380	1500	141	328	3.1	186	2000	1800	3476	8	317	709

Flame size 450mm

Model	Rated Torque	Rated Voltage	Rated Speed	Rated Power	Rated Current	Kt	Ke	Max. Speed	Max. Torque	Rotor Inertia	Poles	Weight	Length
	N.m	Vac	rpm	kW	A	N.m/A	V/krpm	rpm	N.m	Kg.cm ²	poles	Kg	mm
450H11E15C	700	380	1500	110	244	3.1	187	2000	1400	4300	8	370	528
450H16E15C	1000	380	1500	157	330	3.2	196	2000	2000	6140	8	440	628
450H22E15C	1400	380	1500	220	488	3.1	187	2000	2800	7980	8	510	728
450H31E15C	2000	380	1500	314	622	3.5	209	2000	4000	10324	8	622	888

Insulation grade: Class-H; Thermal protection : PT100, with KTY optional; Protection grade: IP65 (except the terminal box);
Wiring method: Terminal box; Cooling method: Oil-cooling or water-cooling; Working standard: Long-term, S1

300mm, 350mm Permanent Magnet AC Servo Motor - Technical Parameters (direct-driven)

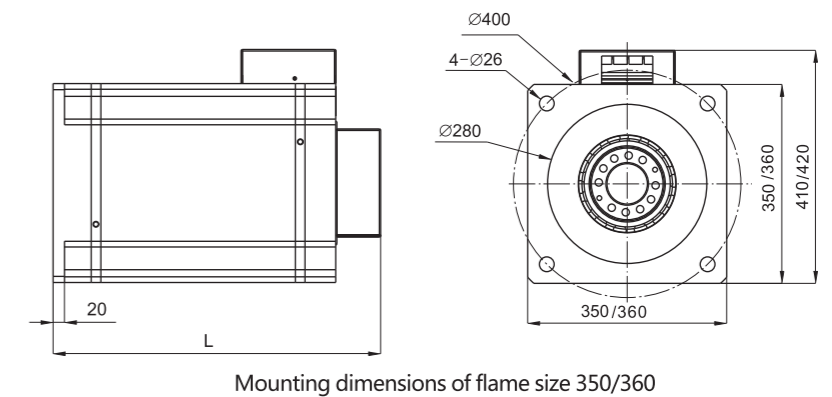
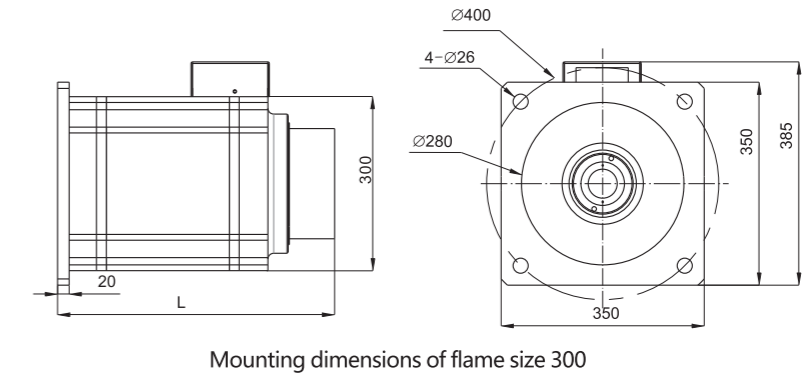
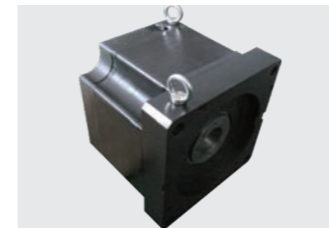

Flame size 300mm

Model	Rated Torque	Rated Voltage	Rated Speed	Rated Power	Rated Current	Kt	Ke	Max. Speed	Max. Torque	Rotor Inertia	Poles	Weight	Length
	N.m	Vac	rpm	kW	A	N.m/A	V/krpm	rpm	N.m	Kg.cm ²	poles	Kg	mm
300H37D35B	1000	380	350	37	91	12.2	740	400	3000	2060	20	133	475
300H55D35B	1500	380	350	55	136	12.2	740	400	4500	3010	20	180	580
300H92D35B	2500	380	350	92	214	12.2	740	400	7500	5000	20	245	780

Flame size 350mm

Model	Rated Torque	Rated Voltage	Rated Speed	Rated Power	Rated Current	Kt	Ke	Max. Speed	Max. Torque	Rotor Inertia	Poles	Weight	Length
	N.m	Vac	rpm	kW	A	N.m/A	V/krpm	rpm	N.m	Kg.cm ²	poles	Kg	mm
350H35D35B	960	380	350	35	88	11.7	710	400	2880	2860	20	148	380
350H55D35B	1500	380	350	55	138	11.7	710	400	4500	3940	20	225	485
350H59D35B	1600	380	350	59	147	11.7	710	400	4800	5560	20	235	530
360H59D35B	1600	380	350	59	147	11.7	710	400	4800	5570	20	245	538

Insulation grade: Class-H; Thermal protection : PT100, with KTY optional; Protection grade: IP65 (except the terminal box);
Wiring method: Terminal box; Cooling method : Natural cooling; Working standard: Long-term, S1

**360mm, 450mm Permanent Magnet AC Servo Motor
- Technical Parameters (direct-driven)**

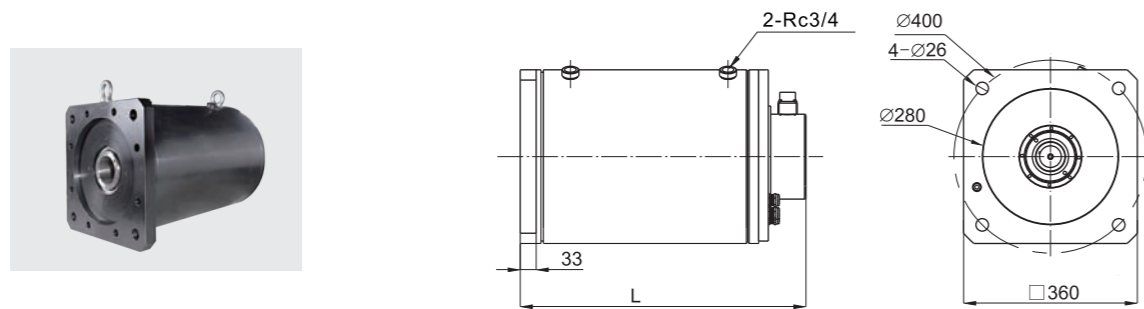

Mounting dimensions of flame size 360

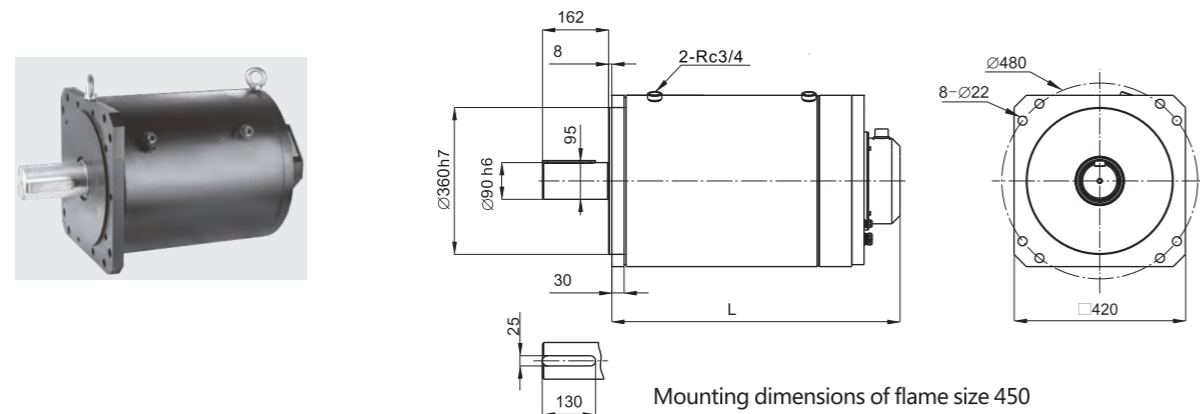

Mounting dimensions of flame size 450

Flame size 360mm

Model	Rated Torque	Rated Voltage	Rated Speed	Rated Power	Rated Current	Kt	Ke	Max. Speed	Max. Torque	Rotor Inertia	Poles	Weight	Length
	N.m	Vac	rpm	kW	A	N.m/A	V/krpm	rpm	N.m	Kg.cm ²	poles	Kg	mm
360H37D35B	1000	380	350	37	91	12.2	740	400	3000	2060	20	190	485
360H55D35B	1500	380	350	55	136	12.2	740	400	4500	3010	20	270	590

Flame size 450mm

Model	Rated Torque	Rated Voltage	Rated Speed	Rated Power	Rated Current	Kt	Ke	Max. Speed	Max. Torque	Rotor Inertia	Poles	Weight	Length
	N.m	Vac	rpm	kW	A	N.m/A	V/krpm	rpm	N.m	Kg.cm ²	poles	Kg	mm
450H44D35B	1200	380	350	44	106	12.1	730	400	3600	6140	8	440	628
450H59D35B	1600	380	350	59	137	12.4	748	400	4800	7980	8	510	728
450H82D35B	2250	380	350	82	197	12.1	732	400	6750	10324	8	620	888

Insulation grade: Class-H; Thermal protection : PT100, with KTY optional; Protection grade: IP65 (except the terminal box);
Wiring method: Terminal box; Cooling method: Oil-cooling or water-cooling; Working standard: Long-term, S1

**630mm Permanent Magnet AC Servo Motors
- Technical Parameters (direct-driven)**

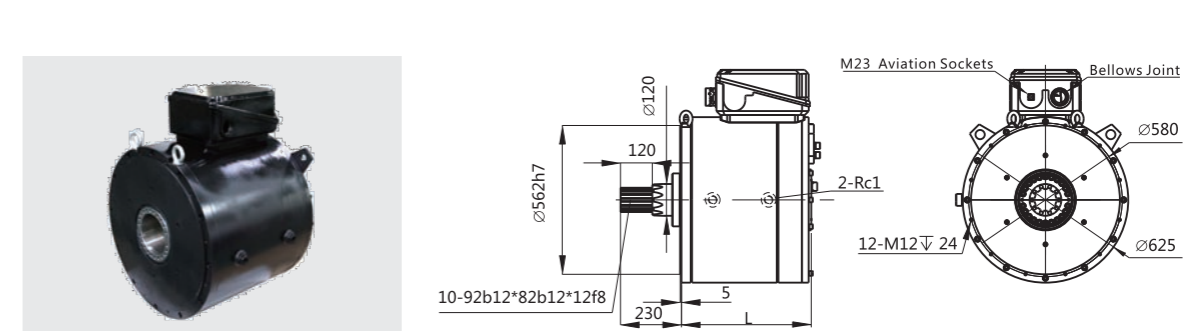

Mounting dimensions of flame size 630(Type A)

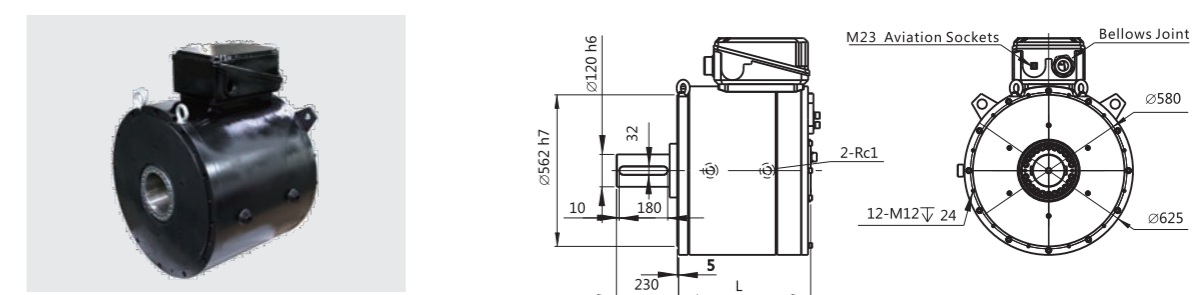

Mounting dimensions of flame size 630(Type B)

Flame size 630mm

Model	Rated Torque	Rated Voltage	Rated Speed	Rated Power	Rated Current	Kt	Ke	Max. Speed	Max. Torque	Rotor Inertia	Poles	Weight	Length
	N.m	Vac	rpm	kW	A	N.m/A	V/krpm	rpm	N.m	Kg.cm ²	poles	Kg	mm
630H63D20B	3000	380	200	63	120	27.0	1630	250	9000	33002	32	640	450
630H75D20B	3600	380	200	75	134	29.1	1759	250	10800	39569	32	706	490
630H88D20B	4200	380	200	88	161	28.3	1709	250	12600	46137	32	772	530
630H10E20B	5000	380	200	105	197	27.4	1659	250	15000	55988	32	863	590
630H13E20B	6300	380	200	132	256	26.6	1609	250	18900	72407	32	1014	690

Insulation grade: Class-H; Thermal protection : PT100, with KTY optional; Protection grade: IP65 (except the terminal box);
Wiring method: Terminal box; Cooling method: Oil-cooling or water-cooling; Working standard: Long-term, S1

Servo Drives

Using high-performance DSP module to control motor current, voltage and speed so as to reach the aim of mechanical automation and energy saving. With features of green design, high performance, high precision and high efficiency, Synmot drives are widely used in injection molding machine, CNC machine tools, textile machines, printing machines etc new energy fields.



NAMING RULES OF SERVO DRIVES

SM 22 -15D C- 0 R C

Mark	Company Code
SM	Synmot in short

Mark	Series
10	General-purpose
21	Water-cooling
22	Generation II Electric-hydraulic
30	General-purpose with EtherCAT
32	Generation III Electric-hydraulic

Mark	Power(W)
Two-digit and one-letter	
A	×1
B	×10
C	×100
D	×1000
E	×10000
EX.75B	750W
EX.15D	15000W

Mark	Voltage
A	1-PH 220V
B	3-PH 220V
C	3-PH 380V
D	3-PH 480V
E	DC 600V
X	Others

Mark	Interface Board
C	CAN
E	EtherCAT
M	RS 485
R	RS 422

Mark	Encoder Type
A	Tamagawa absolute
B	BiSS-C absolut
E	Incremental
H	Heidenhain absolute
R	Resolver
S	Sick absolute
Z	Others

Mark	Design Code
0	Standard
1	Other
2	Overload reinforced

Features

Synmot servo drives adopt the motor dedicated digital processor DSP as the core, and new generation IGBT module to realize high reliability, complete function and easy operation. The drives have high speed field-weakening control function, which effectively extend the operating range of motor, and the system can operate under very low voltage.



Specifications of Servo Drives

	Type	Specification
performance	Speed control bandwidth	≥400Hz
	PWM frequency	4~16kHz
	Pulse input frequency	≤2MHz
	Variable speed ratio	≥1:5000
	Speed fluctuation	< ±0.02% (load 0~100%)
	Overload capacity	≥150% rated current 60s, 180% rated current 6s
Product features	Type of Position feedback	Resolver, Incremental encoder, absolute encoder(Endat, HiperfaceDSL, SmartABS)
	Mode of Speed control	-10V~+10V differential bipolar analog voltage input
		0~+10V unipolar analog voltage input (2-route optional)
		Speed/time curve preset
	Mode of Position control (optional)	RS232/RS485
		Direction + pulse sequence (can replace stepper motor driver)
		90° phase difference two-phase pulse input control(phaseA + phaseB)
	Digital input/output	7programmable input,4 programmable output
	Internal power supply	Internal 10V , 24V power output
	brake function	Internal brake unit,braking ratio is 0 ~ 100%
	Protection function	Overvr voltage, under-voltage, short circuit, over current, overload, overheat in motor and drive, stall, position out of tolerance, encoder/resolver exception, etc.
	Communication function	CANopen field bus
		EtherCAT field bus
		RS485 Modbus, PC connection monitoring
	Other features	Electronic gear control
		Automatic zero detection and gain adjustment
		Automatic acceleration, deceleration and the S-curve control
		Pulse output of rotor position signal, 1-256 frequency division
Others	Cooling method	Nature cooling under 1kW, intelligence air cooled 1.5kW and 160kW , and warer cooling for part of power range
	Level of protection	≤7.5kW IP00, ≥11kW IP20
	Installation method	Wall mountable
Environment	Environment temperature	-10°C- +40°C (Derated if 40°C to 50°C)
	Humidity	5%~95%RH, without condensing
	Vibration	Less than 4.9 m/s (0.5 G) 10~60Hz (non-continnuity)
	Storage temperature	-20°Cto+60°C

Mounting Dimensions of SM30

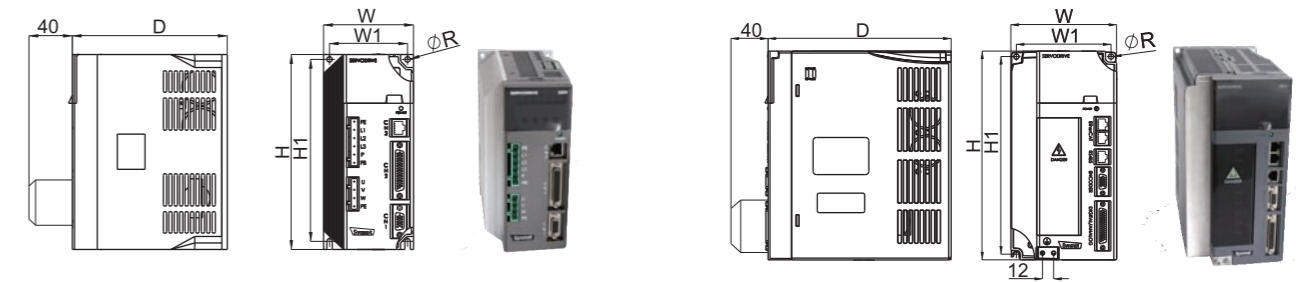

Mounting dimensions of SM30(Type A)

Mounting dimensions of SM30(Type B)

Model	Mounting hole		Dimensions			Mounting hole size	Weight Kg	Type
	W1	H1	H	W	D	R		
SM30-40BB-0	73	170	180	83	144	Φ5	1.4	A
SM30-75BB-0								
SM30-10CB-0								
SM30-15CB-0	74	175	185	90	180	Φ5	2.4	A
SM30-23CB-0								
SM30-33CC-0								
SM30-33CB-0	102	212	225	115	199	Φ6	4	B
SM30-37CC-0								
SM30-44CC-0								
SM30-55CC-0	113	280	295	134	230	Φ6	6.2	B
SM30-75CC-0								
SM30-11DC-0								

Specifications of SM30

Model	Input voltage	Rated power	Rated current	Max current	Motor capacity	Braking resistor	
	Vac	kW	A	A	kW	Ω	
SM30-40BB-0	1PH/3PH AC220V -15%~+10% 50/60Hz	0.4	3	7.1	0.4	-	
SM30-75BB-0		0.75	4	8.5	0.75		
SM30-10CB-0		1	6	9.9	1		
SM30-15CB-0		1.5	8	12.7	1.5		
SM30-23CB-0		2.3	11	19.8	2.2		
SM30-33CB-0		3.3	14	25	3.3		
SM30-33CC-0		3.3	8.5	15	3.3		-
SM30-37CC-0		3.7	10	18	3.7		≥100
SM30-44CC-0		4.4	12	21.5	4		≥100
SM30-55CC-0		5.5	14	25	5		≥70
SM30-75CC-0	7.5	17	31	7.5			
SM30-11DC-0	11	25	45	11			

Note: The rated current is tested on PWM frequency of 8kHz (0.4-2.3kW), 6kHz (>3kW)

Mounting Dimensions of SM22/SM30

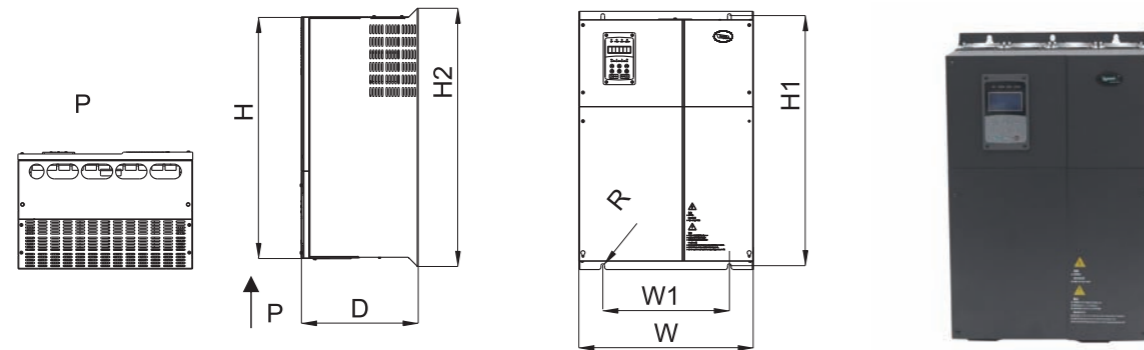

Mounting dimensions of SM22/SM30

Model	Mounting hole		Dimensions				Mounting hole size	Weight Kg
	W1	H1	H	H2	W	D	R	
SM22-11DC-2	187	315	307	330	230	180	Φ7	12
SM22-15DC-0			339	373				
SM22-18DC-0			358	397				
SM22-22DC-0	187	358	339	373	250	195	Φ7	13
SM22-22DC-2			397	430				
SM22-30DC-0			430	460				
SM22-37DC-0	235	445	430	460	285	226	Φ8	21
SM22-37DC-2			460	490				
SM22-45DC-0			490	520				
SM22-55DC-0	245	525	484	540	324	275	Φ10	32
SM22-55DC-2			540	590				
SM22-65DC-0			590	640				
SM22-75DC-0	260	580	544	600	384	265	Φ10	40
SM22-75DC-2			600	650				
SM22-90DC-0			650	700				
SM22-11EC-0	343	680	654	690	470	300	Φ10	66
SM22-13EC-0			684	740				
SM22-13EC-0	343	686	684	740	516	322	Φ12	76

Specifications of SM22/SM30

Model	Input voltage	Rated power	Rated current	Max current	Motor capacity	Braking resistor
	Vac	kW	A	A	kW	Ω
SM22-11DC-2	3PH AC380V -15%~+10% (50/60Hz)	11	25	45	7.5~11	≥32
SM22-15DC-0		15	32	51	13~15	
SM22-18DC-0		18.5	37	67	18.5	
SM22-22DC-0		22	45	81	22	≥25
SM22-22DC-2		22	46	85	22	
SM22-30DC-0		30	60	99	25~30	
SM22-37DC-0		37	75	135	34~37	≥16
SM22-37DC-2		37	78	145	34~37	
SM22-45DC-0		45	90	159	42~45	
SM22-55DC-0		55	115	202	47~55	≥8
SM22-65DC-0		65	130	240	56~65	
SM22-75DC-0		75	150	270	66~75	
SM22-90DC-0		90	175	318	76~90	≥6
SM22-11EC-0		110	205	378	92~110	
SM22-13EC-0		132	250	450	110~132	

Note: The rated current is tested on PWM frequency 6 KHz, Rated power ≥100kW, 4kHz.

Wiring Diagram of SM General-purpose Servo

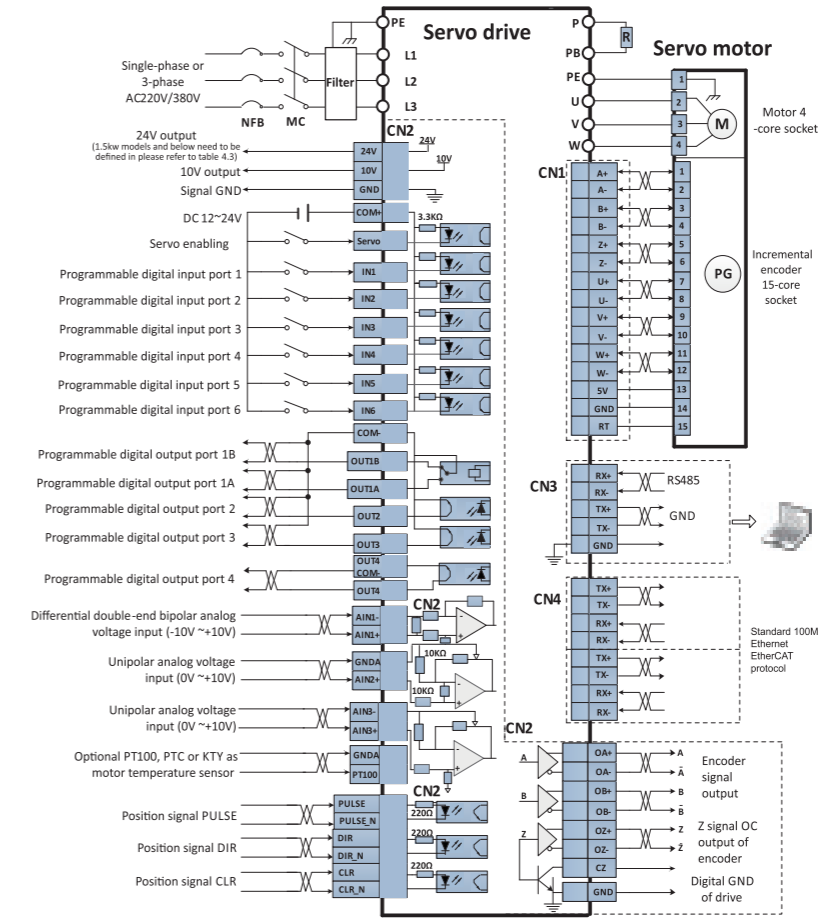

Wiring Diagram of SM22 Electro-hydraulic Servo

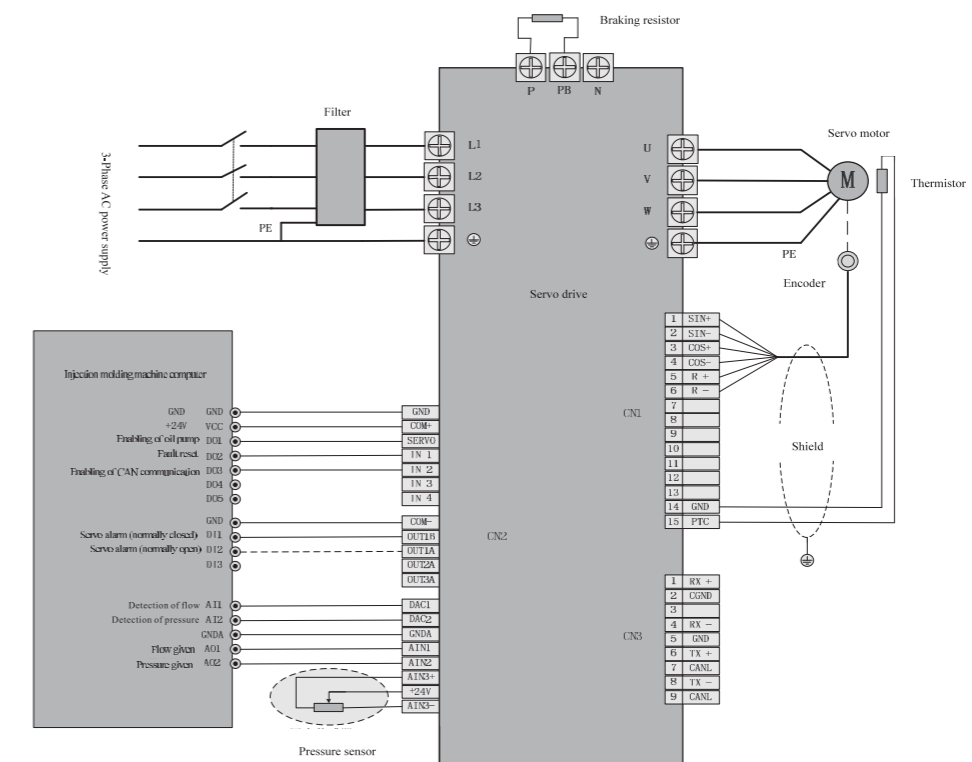

Electro Hydraulic Servo Systems

Synmot is one of leading manufacturers of servo systems in china who provide one-stop service. The products are with stable performance, high precision and excellent energy saving. Electro hydraulic servo systems have been fully tested to ensure the perfect matching of servo motors, servo drives and oil pumps.



NAMING RULES OF ELECTRO HYDRAULIC SERVO SYSTEMS

SM-0090 M 0067 Q - 0 1 1

Mark	Company Code
SM	Synmot in short

Mark	Tonnage
0~9999	Ton

Mark	Pressure
L	14MPa
M	16MPa
H	17.5MPa
S	21MPa

Mark	Flow
0~9999	L/min

Mark	Pump
Q	Sumitomo
E	Eckerle
F	Voith
X	Other

Mark	Drive
1	Standard
0	1-level down
2	1-level up
3	2-level up

Mark	Motor
1	Standard
0	1-level down
2	1-level up
3	2-level up

Mark	Design
0	Standard
1	Internal code
2	Internal code
3	Internal code

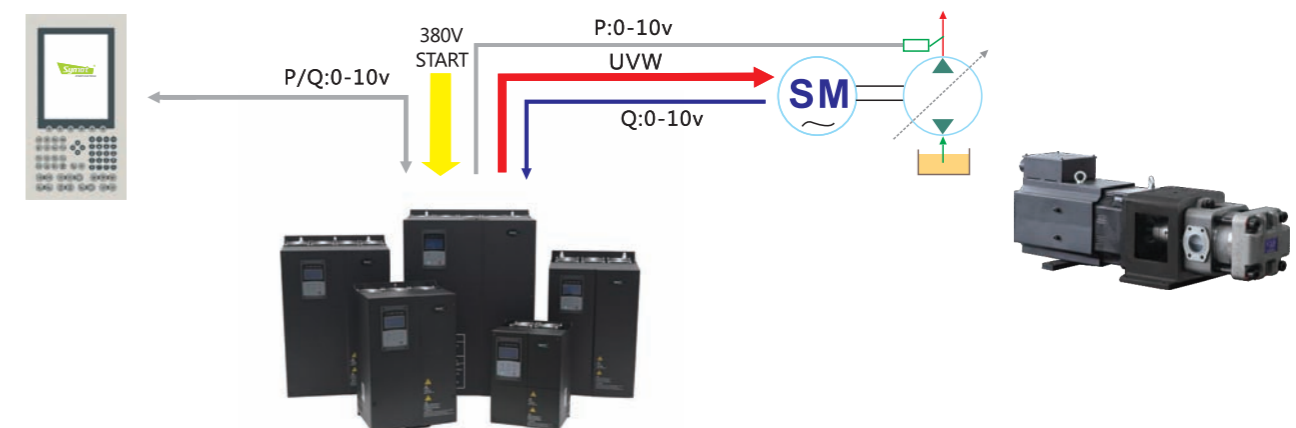

Specifications of Electro Hydraulic Servo Systems

Flow	Pump outlet volume	cc/r	25	32	40	50	63	80	100	125	160		
	Standard flow	L/min	53	67	84	105	132	160	200	250	342		
	Max. flow	L/min	63	75	96	120	150	200	250	310	400		
	Linear	%	≤1%F.S										
Pressure	Magnetic-lag	%	≤1%F.S										
	Max. pressure	Mpa	14 16 18	14 16 18	14 16 18	14 16 18	14 16 18	14 16 18	14 16 18	14 16 18	14 16 18	14 16 18	
	Min. pressure	Mpa	0.1										
	Linear	%	≤1%F.S										
Motor	Magnetic-lag	%	≤1%F.S										
	Rated torque	N.m	48 48 48	70 70 70	70 70 96	96 96 118	118 118 140	140 140 169	169 191 208	208 236 264	264 286 315		
	Insulation level		H										
	Protection level		IP65										
Drive	Cooling method		Forced-air cooling										
	Environmental temperature		-10°C ~ +40°C (Derated if 40°C to 50°C)										
	Environmental humidity		20-90%RH (Non-condensing)										
	Weight of moter and pump	Kg	63 63 63	70 70 70	75 75 82	105 105 116	116 116 125	125 125 243	243 248 253	253 259 265	275 290 302		
Drive	Rated power	kW	11 11 11	11 11 11	15 15 22	22 22 22	22 22 30	30 30 37	37 45 45	45 45 55	55 55 65		
	Input voltage range	Vac	3PH 380~440VAC 50/60Hz										
	Control method		SVPWM Control										
	Brake unit		Built-in as standard										
	Feedback type		Speed detection-Resolver, pressure detecion-pressure sensor										
	Pressure command input		0~10V with software correction										
	Pressure feedback output		0~10V										
	Flow command order input		0~10V with software correction										
	Multifunctional input signal		6 programmable input and 1 enable, DC24V 8mA										
	Multifunctional output signal		4 programmable output DC24V 30mA										
	Protect functions		Over voltage, under-voltage, short circuit, over current, overload, overheat in motor and drive, stall, position out of tolerane encoder/resolver error, etc.										
	Communication functions		CAN communication through CANopen protocol; RS485 communication through MODBUS protocol; Industrial ethernet communication through EtherCAT										
	Cooling method		Intelligent air cooling										
	Environmental temperature		-10°C ~ +40°C (Derated if 40°C to 50°C)										
	Environmental humidity		5%~95%RH , without condensing										
	Weight	Kg	11	11	11	11 22 22	22	22	35	30	30 45 45		
Oil	Actuating medium		HL-HLP DIN51 524 Part1/2 R68 R46										
	Operation temperature	°C	-20 to 100										
	Tackiness		@40°C	67.83									@100°C

Configuration Examples

Model	System flow (L/min)	System pressure (Mpa)	Matching Machine	Rated torque of motor(N.m)	Pump volume (cc/r)	Servo motors	Servo drives
SM-0060M0045H-111	53	16	60T	48	25	SM-190H75C15C-Rn21F	SM22-75CC-ORC
SM-0090M0067Q-121	67	16	90T	70	31.5	SM-190H11D15C-Rn21F	SM22-11DC-ORC
SM-0120M0084Q-121	84	16	120T	70	40	SM-200H13D17C-Rn21F	SM22-15DC-ORC
SM-0160M0105Q-122	105	16	160T	96	50	SM-200H17D17C-Rn21F	SM22-22DC-ORC
SM-0200M0132Q-121	132	16	200T	118	63	SM-200H21D17C-Rn21F	SM22-30DC-ORC
SM-0260M0168Q-111	160	16	260T	140	80	SM-200H25D17C-Rn21F	SM22-30DC-ORC
SM-0300M0210Q-121	200	16	300T	210	100	SM-260H34D17C-Rn21F	SM22-37DC-ORC
SM-0360M0231Q-111	250	16	360T	265	125	SM-260H42D17C-Rn21F	SM22-45DC-ORC

EMI Filters for Servo Applications

Product Features

- ▲ Developed for servo applications, with excellent interference, conduction filtering effect, excellent low frequency attenuation, and common mode and differential mode rejection capability, can effectively protect the servo drives and improve the anti-interference ability;
- ▲ New magnetic materials are used in common-mode and differential-mode inductors, capacitors and other electronic materials are highly reliable and quality guaranteed, to comply with international standards;
- ▲ The surge absorption capacity is strong while the leakage current is relatively small;
- ▲ Small volume, light weight, easy installation.



Technical Parameters

- ▲ Rated voltage: 415±15%VAC;
- ▲ Frequency: 50/60Hz;
- ▲ Leakage current: < 2.0 mA @250VAC/50Hz;
- ▲ Working temperature: -25°C~+125°C.

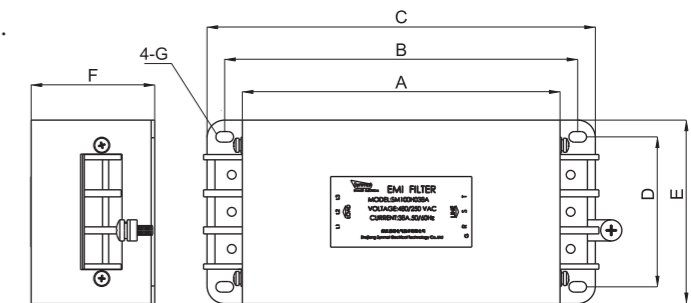

Modle	Rated current			Mounting hole			Dimensions				Mounting hole sizeWeight	
	A	B	D	A	C	E	F	G	Kg			
SM101H038A	38	200	85	178	220	100	67	6×10	1.9			
SM101H050A	50	200	85	178	220	100	86	6×10	2.3			
SM101H065A	65	200	85	178	220	100	86	6×10	2.5			
SM101H085A	85	278	85	218	304	130	90	8×16	3.3			
SM101H120A	120	278	85	218	304	130	90	8×16	3.5			
SM101H150A	150	345	138	304	371	188	100	8×16	6.8			
SM101H180A	180	345	138	304	371	188	100	8×16	7.0			

Performance Parameters

Model	Frequency (MHz)	Common-mode insertion loss (dB)							Differential-mode insertion loss (dB)						
		0.1	0.15	0.5	1	5	10	30	0.1	0.15	0.5	1	5	10	30
SM101H038A		18.5	26.6	44.8	49.4	43.2	37.5	26.4	23.2	27.1	50.6	55.1	38.5	32.7	24.0
SM101H050A		23.7	31.2	53.8	58.9	40.4	34.3	23.1	26.2	23.2	56.7	58.5	39.6	34.5	25.0
SM101H065A		23.7	31.2	53.8	58.9	40.4	34.3	23.1	26.2	23.2	56.7	58.5	39.6	34.5	25.0
SM101H085A		24.5	33.4	56.2	58.8	43.4	37.5	25.9	21.8	35.0	54.8	59.7	38.4	33.0	22.1
SM101H120A		24.5	33.4	56.2	58.8	43.4	37.5	25.9	21.8	35.0	54.8	59.7	38.4	33.0	22.1
SM101H150A		40.0	46.9	61.5	59.5	40.7	35.5	23.5	28.7	45.8	55.9	57.5	38.1	30.8	25.2
SM101H180A		40.0	46.9	61.5	59.5	40.7	35.5	23.5	28.7	45.8	55.9	57.5	38.1	30.8	25.2